

Things to Know



9.1	Technical Basics	3
9.1.1	General Processing Guidelines	3
9.1.2	Addresses	7
9.1.3	Standards	8
9.2	Preliminary static design	11
9.2.1	Glass supports	11
9.2.2	Transom connector	24
9.3	Tests / Authorisations / CE Mark	33
9.3.1	Demand for tested and approved products	33
9.3.2	Overview of all tests and approvals	34
9.3.3	BauPV / DOP / ITT / FPC / CE	38
9.3.4	DIN EN 13830 / Explanations	43
9.4	Thermal insulation	49
9.4.1	Introduction	49
9.4.2	Standards	50
9.4.3	Basis of the calculation	51
9.4.4	U_f values	69
9.5	Humidity protection	81
9.5.1	Humidity protection in the glass facade	81
9.6	Sound insulation	89
9.6.1	Sound insulation in the glass facade	89
9.7	Fire protection	93
9.7.1	Overview	93
9.7.2	Construction law / Standardisation	94
9.8	Burglary-resistant facades	105
9.8.1	Burglary-resistant facades	105
9.8.2	Burglary-resistant facades - RC2	108

By EFTCG

NODDEN

F A C A D E

General Processing Guidelines

9.1
1

Miscellaneous

In addition to the processing instructions for the respective Norden Facade systems, it is also important to consider the regulations in place for the steel and glass-processing industries. We also refer to the importance of adhering to the applicable standards. Neither the standards and rules listed in the following nor the index of addresses make any claim to completeness. European standards have been and will continue to be introduced within the process of European harmonisation. In places they will replace national standards. We make efforts to ensure that our processors are up-to-date with standards. It is nevertheless the responsibility of the user to obtain information on the latest standards and rules that are important to their work.

Technical advice, support in planning and quotations

All suggestions, tender, design and installation proposals, material calculations, static calculations and such like provided by Norden Facade employees in the course of consultancy, correspondence or the preparation of documents are submitted in good faith and to the best of their knowledge. Processors must review such ancillary services critically and seek approval from the principal or architect if necessary.

Requirements in regard to operation, storage, processing and training

Companies must possess equipment designed for the processing of steel and aluminium in order to manufacture flawless components. This equipment must be designed in such a way that any damage to the profiles during processing, storage and removal is avoided. All components must be stored dry; in particular, they must be kept away from building detritus, acids, lime, mortar, steel shavings and such like. In order to satisfy the requirements of the latest technology, employees must be enabled to acquire the necessary training through literature, courses or seminars.

The processing company is solely responsible for calculating all dimensions. It is also necessary to carry out and commission the review of static calculations of the load-bearing profiles and anchoring and to validate details, connections and such like in diagrams.

Glass

The glass type is selected based on the mandatory requirements of structural engineering. The glass thicknesses must be defined according to the “Technical rules for linearly mounted glazing wind”, with due consideration of the wind loads.

Glazing must be installed in a materially and technically correct manner in accordance with the relevant standards.

Cleaning / maintenance

Although cleaning of the glass surfaces themselves is not part of their maintenance, it is nevertheless essential to ensure the good working order and service life of the products.

Cleaning and protection during the building phase

- The contractor is responsible for cleaning during the building phase. The mounted elements should be cleaned thoroughly before acceptance.
- Coarse dirt must be cleaned off immediately using sufficient water.
- Any cleaning performed must be compatible with the materials.
- Standard solvents such as methylated spirits or isopropanol can be used to remove sealant residue.
- Anodized aluminium parts must be protected before non-hardened plaster, mortar or cement are applied, i.e. any residue must be removed immediately, as the alkali reactions they cause may otherwise cause irremovable staining.
- Mechanical damage to the anodised surface cannot be repaired. You are therefore advised to handle the aluminium parts with care.
- For this reason, we recommend you take suitable precautionary measures. Adhesive plastic foil, peelable lacquer or self-weathering clear varnish provide a degree of protection. Any adhesive tape applied must be compatible with the surfaces; particular care must be taken with painted surfaces in this respect.

General Processing Guidelines

9.1
1

Cleaning after acceptance and during permanent use

The client is responsible for proper cleaning after acceptance, i.e. after partial acceptance already; it is important to clean all accessible components at this point.

- Clean, warm water should be used for cleaning in order to prevent any scratching by the dirt particles.
- Removal of adhesive labels and spacers
- Neutral (pH values between 5 and 8) household and glass detergents also help. Alkali and acidic chemical detergents and any containing fluoride must not be used. It is imperative to avoid destroying the corrosion protection on the components.
- Grease and sealant residue can be removed using standard solvents (methylated spirits, isopropanol). The use of benzene and other thinners is not permitted, as they may cause irreparable damage.
- Use of clean and soft cleaning sponges, cloths, leather cloths or squeegees. All scouring materials and abrasive detergents are unsuitable and cause permanent damage.
- The manufacturer's instructions must be adhered to on all accounts in the handling of coated glass and single-pane security glass.
- It is permitted to use neutral detergents with added polish on painted surfaces (e.g. car polish). These agents must be silicone-free; test them first on a concealed surface.
- The seals are essentially maintenance-free. Their durability can be ensured by the use of special cleaning lotion to prevent the material from becoming brittle.
- The manufacturer's instructions must be adhered to in particular for all fitted parts such as timber and aluminium windows and doors. The rebates must be cleaned on all accounts and spaces must be left to allow water to run off.

Cleaning intervals

Cleaning should be performed regularly, depending on the level of environmental pollution. Basic cleaning must be performed at least once annually. Norden Facade recommends 6-monthly cleaning in order to preserve the attractive appearance of painted surfaces, i.e. the structure as a whole.

Maintenance

Facades and their fitted parts such as windows and doors must remain in permanent good working order. Mandatory measures to preserve good working order and to prevent material and personal damage are defined in the national construction codes and construction product ordinances.

The generic term 'maintenance' describes the areas of servicing/care, inspection, repair and improvements. The following addresses the topics of servicing/care and inspection in greater detail. These factors are essential to guarantee fitness for purpose and secure use and hence to ensure sustainable preservation of value. Accessibility for subsequent maintenance must be included in the planning of a construction project or refurbishment.

Particular reference is made at this point to VFF the leaflets WP.1 – WP.5 by Verband der Fenster- und Fassadenhersteller e.V. They contain information for windows / doors and other installations, as well as templates for contracts and correspondence. Information and templates can also be obtained from ift – Institut für Fenster-technik Rosenheim. The contact details are listed in the address section.

General Processing Guidelines

9.1
1

Servicing/care and inspection obligations

The facade manufacturer (contractor) accepts the warranty for the supplied and installed products after acceptance as defined in the contractual undertakings. The warranty will be void in the event that a failure to perform servicing and care properly or at all leads to defects and damage. This applies also to the improper use of a component.

The contractor is not automatically obliged to provide servicing/care and inspection if there is no specific contractual agreement to do so. The national construction codes make it the duty of the principal/owner to maintain the construction products and components. The client must inform the principal/owner in this respect if they are not the same person/entity. The contractor deals at all times only with the client.

However, the contractor is obliged to make the client aware of maintenance issues. It is advisable to fulfil this duty in writing before the contracts are signed and to submit more detailed updates as the building work progresses. All documents on this issue must be submitted no later than upon presentation of the final invoice. Alternatively, the contractor can offer a maintenance contract and therein accept contractually defined servicing/care and inspection duties. The obligation to perform maintenance begins with the acceptance.

Maintenance measures

All components must be checked to ensure their fitness for purpose, as well as for deformation and damage. All facilities relevant to safety must be checked. Damage must be repaired immediately.

Fixed glazing on facades

- Material-specific examination of the supporting profiles for damage and deformation. e.g.: Metal: Weld seams, open joints, cracks, mechanical strength.
- Timber: Timber flaws (loose knots and protruding knot plugs); moisture damage, fungus and/or insect infestation, open joints, cracks, mechanical strength.
- Check of component connections (e.g. mullion/transom connections), reinforcements and structural attachments (e.g. connection plates, assuming they are accessible when installed).
- Check of structural attachment joints and seals.
- Assessment of the filling elements (panes, panels) to ensure proper mounting and absence of damage.
- Check of seals for proper mounting, sealant properties and ageing caused by brittleness.
- Test of the clamp connection to hold the filling elements. They include the screw fittings and clip strips.
- Visual inspection of the surface of the structure (coatings, corrosion).
- Good working order of all drainage systems, component ventilation systems and pressure equalisation openings.

General Processing Guidelines

9.1
1

Movable facade components

Roller blinds, ventilation, movable and rigid solar shading are fitted to facades in addition to doors and windows. These components must be checked in the same way as the fixed glazing elements. Moreover, all parts with relevance to safety and moving parts must be assessed to ensure they are mounted properly, are in good working order and do not exhibit wear. They include:

- Drive units (manual, electric)
- Fittings
- Door hinges
- Locking parts and latches
- Screw fittings
- Lubrication/greasing to ensure smooth operation of movable parts

The manufacturer's instructions must be adhered to in particular for all fitted parts.

Recommended inspection intervals		
	Safety-relevant inspection	General inspection
School or hotel buildings	6-monthly	6-monthly / yearly
Office and public buildings	6-monthly / yearly	yearly
Residential buildings	yearly / every 2 years	yearly / every 2 years / measures as stipulated by the client

Maintenance protocol

A protocol must be kept of the findings of the inspection, the implementation of servicing and care and the necessary repairs. It must list all checked parts/components and contain specific and general comments. Information on the property, the component and its precise location in the building must be recorded in order to ensure clear allocation.

VFF leaflet WP.03 also has form templates designed for this purpose.

Inspection intervals

The following table contains recommended inspection intervals, published as an assistance by ift Rosenheim. The distinction between "safety-relevant" and "general" inspections refers to fittings.

Norden Facade recommends an interval of one year for fixed glazing.

The manufacturer's instructions are authoritative for installed parts. VFF leaflet WP.03 provides form templates for components requiring maintenance and intervals for the materials used.

Product documents

You will find all of the information you require on Norden Facade systems in our catalogue documents. The sections "Sys-tem" and "Processing Instructions" contain important information in particular.

The product information, operating instructions, servicing/care instructions and cleaning recommendations published by the respective manufacturer must be adhered to for other components.

Addresses

9.1
2

Verband der Fenster- und Fassadenhersteller e.V.
Walter-Kolb-Straße 1-7
60594 Frankfurt am Main
www.window.de

Informationsstelle Edelstahl Rostfrei
Sohnstr. 65
40237 Düsseldorf
www.edelstahl-rostfrei.de

DIN Deutsches Institut für Normung e.V.
Burggrafenstraße 6
10787 Berlin
www.din.de

Institut für Fenstertechnik e.V. (ift)
Theodor-Gietl-Straße 7-9
83026 Rosenheim
www.ift-rosenheim.de

DIN standards, available from Beuth-Verlag GmbH
Burggrafenstraße 6
10787 Berlin
www.beuth.de

Bundesverband Metall-Vereinigung
Deutscher Metallhandwerke
Ruhrallee 12
45138 Essen
www.metallhandwerk.de

DIN Deutsches Institut für Normung e.V.
Kolonnenstraße 30 L
10829 Berlin
www.dibt.de

GDA, Gesamtverband der Aluminiumindustrie e.V.
Am Bonneshof 5
40474 Düsseldorf
www.aluinfo.de

Bundesinnungsverband des Glaserhandwerks
An der Glasfachschule 6
65589 Hadamar
www.glaserhandwerk.de

Deutsche Forschungsgesellschaft für
Oberflächenbehandlung e.V.
Arnulfstr. 25
40545 Düsseldorf
www.dfo-online.de

Deutscher Schraubenverband e.V.
Goldene Pforte 1
58093 Hagen
www.schraubenverband.de

Passivhaus Institut
Dr. Wolfgang Feist
Rheinstr. 44/46
64283 Darmstadt
www.passiv.de

Standards

9.1
3

Index of applicable standards and regulations

DIN EN 1993	Design of steel structures
DIN EN 1995	Design of timber structures
DIN EN 1991	Actions on structures
DIN EN 572	Glass in building
DIN EN 576	Aluminium and aluminium alloys
DIN EN 573	Aluminium and aluminium alloys (wrought and cast alloys)
DIN EN 485	Aluminium and aluminium alloys - Sheet, strip and plate
DIN EN 755	Extruded aluminium profiles and wrought aluminium profiles
DIN 1960	German construction contract procedures (VOB) - Part A
DIN 1961	German construction contract procedures (VOB) - Part B
DIN 4102	Fire behaviour of building materials and building components
DIN 4108	Thermal insulation and energy economy in buildings
DIN 4109	Sound insulation in buildings
DIN EN 1999	Design of aluminium structures
DIN EN 12831	Heating systems in buildings – Method for calculation of the design heat load
DIN 7863	Elastomer glazing and panel gaskets for windows and claddings
DIN 16726	Plastic sheets - Testing
DIN EN 10025	Hot rolled products of structural steels
DIN EN 10250	Open die steel forgings for general engineering purposes
DIN 17611	Anodized products of aluminium and wrought aluminium alloys
DIN EN 12020	Aluminium and aluminium alloys - Extruded precision profiles in alloys EN AW-6060 and EN AW-6063
DIN 18055	Window joint permeability, watertightness and mechanical load
DIN 18273	Building hardware - Lever handle units for fire doors and smoke control doors - Terms and definitions, dimensions, requirements, testing and marking
DIN 18095	Smoke control doors
DIN EN 1627-1630	Pedestrian doorsets, windows, curtain walling, grilles and shutters - Burglar resistance - Requirements and classification
DIN 18195 T9	Waterproofing of buildings, penetration, transitions, barriers
DIN 18202	Tolerances in building construction - Buildings
DIN 18203	Tolerances in building construction
DIN 18335	German construction contract procedures (VOB) - Part C - General technical specifications for steel construction works
DIN 18336	German construction contract procedures (VOB) - Part C - Sealing work
DIN 18357	German construction contract procedures (VOB) - Part C - Fittings work
DIN 18360	German construction contract procedures (VOB) - Part C - Metal work, fitter work
DIN 18361	German construction contract procedures (VOB) - Part C - Glazing work
DIN 18364	German construction contract procedures (VOB) - Part C - Corrosion protection on steel and aluminium structures
DIN 18421	German construction contract procedures (VOB) - Part C - Insulation and fire protection work on technical systems
DIN 18451	German construction contract procedures (VOB) - Part C - Scaffolding work
DIN 18516	Cladding for external walls
DIN 18540	Sealing of exterior wall joints in building using joint sealants
DIN 18545	Sealing of glazing with sealants

Standards

9.1
3

Index of applicable standards and regulations

DIN EN ISO 1461	Hot dip galvanized coatings
DIN EN 12487	Corrosion protection of metals - Rinsed and non-rinsed chromate conversion coatings on aluminium and aluminium alloys
DIN EN ISO 10140	Acoustics - Laboratory measurement of sound insulation of building elements
DIN EN 356	Glass in building - Security glazing - Testing and classification of resistance against manual attack
DIN EN 1063	Glass in building - Security glazing - Testing and classification of resistance against bullet attack
DIN EN 13541	Testing and - Security glazing - classification of resistance against explosion pressure
DIN 52460	Sealing and glazing
DIN EN ISO 12567	Thermal performance of windows and doors - Determination of thermal transmittance by the hot-box method
DIN EN ISO 12944	Corrosion protection of steel structures by protective paint systems
DIN 55634	Paints, varnishes and coatings - Corrosion protection of steel structures
DIN EN 107	Test procedures for windows: mechanical test
DIN EN 573-1-4	Aluminium and aluminium alloys - Chemical composition and form of wrought products
DIN EN 755-1-2	Aluminium and aluminium alloys - Extruded rod/bar, tube and profiles
DIN EN 1026	Windows and doors - Air permeability - Test method
DIN EN 1027	Windows and doors - Watertightness - Test method
DIN EN 10162	Cold-rolled steel sections - Technical delivery conditions - Dimensional and cross-sectional tolerances
DIN EN 949	Windows and curtain walling, doors, blinds and shutters - Determination of the resistance to soft and heavy body impact for doors
DIN EN 1363-1	Fire resistance tests for non-loadbearing elements
DIN EN 1364-1	Fire resistance glazing, requirements and classification
DIN EN ISO 1461	Hot dip galvanized coatings on steel; requirements and testing
DIN EN 1522	Bullet resistance for windows, doors and barriers (requirements and classification)
DIN EN 1523	Bullet resistance for windows, doors and barriers (requirements and test methods)
DIN EN 1627	Burglar resistance for windows, doors and barriers (requirements and classification)
DIN EN 1628	Burglar resistance for windows, doors and barriers (test method for determination of resistance under dynamic loading)
DIN EN 1629	Burglar resistance for windows, doors and barriers (test method for determination of resistance under static loading)
DIN EN 1630	Burglar resistance for windows, doors and barriers (test method for determination resistance to manual burglary attempts)
DIN EN 1991-1-1	Eurocode 1, Actions on structures
DIN EN 1993-1-1	Eurocode 3, Design of steel structures
DIN EN 1995-1-1	Eurocode 5, Design of timber structures
DIN EN 10346	Continuously hot-dip coated steel flat products for cold forming
DIN EN 10143	Continuously hot-dip coated steel sheet and strip
	Tolerances on dimensions and shape
DIN EN 12152	Curtain walling - Air permeability - Performance requirements and classification
DIN EN 12153	Curtain walling - Air permeability - Test methods

Standards

9.1
3

Index of applicable standards and regulations

DIN EN 12154	Curtain walling - Watertightness - Performance requirements and classification
DIN EN 12155	Curtain walling - Watertightness - Laboratory test under static pressure
DIN EN 12179	Curtain walls - Resistance to wind load - Test methods
DIN EN 12207	Window und doors - Air permeability - Classification
DIN EN 12208	Window und doors - Watertightness - Classification
DIN EN 12210	Window und doors - Resistance to wind load - Classification
DIN EN 12211	Windows and doors - Resistance to wind load - Test methods
DIN EN 13116	Curtain walls - Resistance to wind load - Performance requirements
DIN EN 13830	Curtain walls - Product standard
DIN EN 14019	Curtain walls - Impact resistance
DIN EN ISO 12631 12631-01:2013	Thermal performance of windows and doors - Determination of thermal transmittance - Simplified procedure
DIN 18200	Assessment of conformity for construction products - Initial type testing and factory production control, Certification of construction products by certification body
DIN 18008	Glass in Building - Design and construction rules for the use of fall-secured glazings
DIN 18008	Construction rules for linearly supported glazings
EnEV	Energy Saving Ordinance

Guidelines for the Design and Application of Roof Waterproofing

Guideline for GSB Steel Coating

Bundesinnungsverband des Glaserhandwerks

Leaflets by Stahl-Informations-Zentrum, Düsseldorf

Glass supports

9.2
1

Miscellaneous

- Glass supports are used to transfer the self-weight loads exerted by the glazing into the transom of a facade system.
- Fitness for purpose is usually authoritative in the selection of a glass support; it is usually defined by a limit value of glass support deflection.
- The load-bearing capacity is frequently several times the load defined as limit value for deflection.
- Therefore, a failure of the facade structure and a risk of personal injury are excluded under normal circumstances. This is why the building inspectorate has not defined any particular requirements for the use of glass supports and their connections.

The glass supports and glazing are positioned according to glass industry guidelines and guidelines of ift Rosenheim. The reference value for attaching the glass support is approx. **100 mm** from the end of the transom. The additional information contained in Section 1.2.7 – Processing information must be observed.

The glass supports that Norden Facade can deliver are component tested for load-bearing capacity and fitness for purpose. These tests were conducted by the firm Feldmann + Weynand GmbH in Aachen. The tests were performed in the experiments hall for steel and lightweight metal structures at RWTH Aachen.

The measured deflection of $f_{\max} = 2 \text{ mm}$ below the theoretical point of attack exerted by the consequent pane weight was applied as the limit value for glass support deflection. The location of the point of attack is identified using eccentricity “e”.

Glass support types und timber types

The Norden Facade H and Norden Facade ZL systems distinguish between two different types and techniques for attaching glass supports:

- Glass support GH 5053 and GH 5055 with hanger bolts.
- Glass support GH 5053 and GH 5055 with hardwood cylinders and bolts.

Solid timber (VH) or laminated timber (BSH) made of softwood (NH) can be used as profiles. The following strength classes are tested according to DIN 1052:

- VH (NH) strength class C24 (minimum rated value or pressure at right angles to the fibre = 2.50 N/mm²),
- BSH (NH) strength class GL24h (minimum rated value or pressure at right angles to the fibre = 2.70 N/mm²),

Eccentricity “e”

The height of the inner seal and the glass structure, i.e. the centre of gravity of the glass pane is determined by the eccentricity “e”. The unit “e” describes the distance between the front edge of the timber transom and the theoretical load transfer line.

Glass supports

9.2
1

Diagram of the glass structure / Abbreviations used

Symmetrical glass structure Example of System H

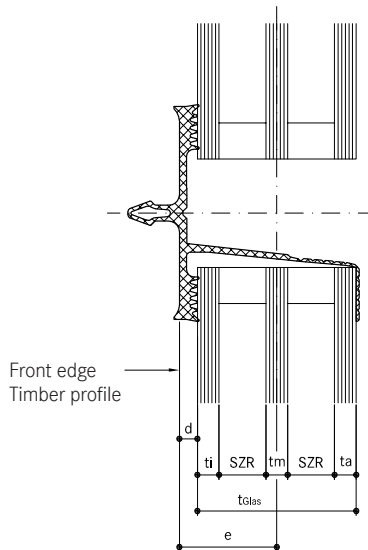

- d = Height of the inner seal
- ZL = Height of the spacer strip (10 mm)
- t_{Glass} = Total glass thickness
- ti = Thickness of the inner pane
- tm = Thickness of the middle pane
- ta = Thickness of the outer pane
- SZR₁ = Space between panes 1
- SZR₂ = Space between panes 2
- a₁ = Distance from the front edge of the timber profile to the centre of the inner pane
- a₂ = Distance from the front edge of the timber profile to the centre of the middle pane
- a₃ = Distance from the front edge of the timber profile to the centre of the outer pane
- G = Pane weight
- G_L = Load share

Asymmetrical glass structure Example AK-H system

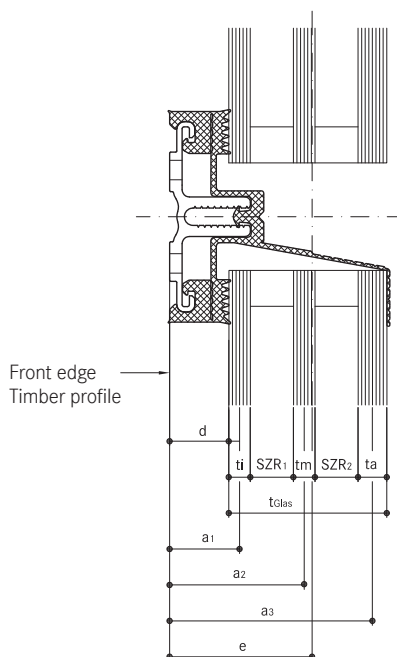

Asymmetrical glass structure Example ZL-H system

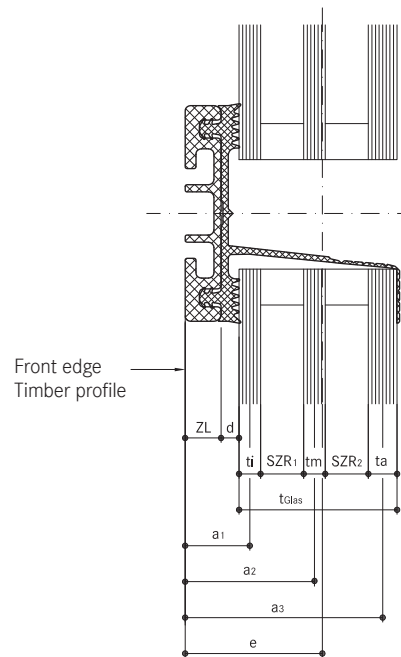

Glass supports

9.2
1

Identification of the permitted pane weight

1. Calculation of the pane weight

Surface of the pane = $W \times H$ in [m²]
 Aggregate glass thickness = $t_i + t_m + t_a$ [m]
 Specific glass weight = $\gamma \approx 25.0$ [kN/m³]

→ Pane weight [kg] = $(W \times H) \times (t_i + t_m + t_a) \times \gamma \times 100$

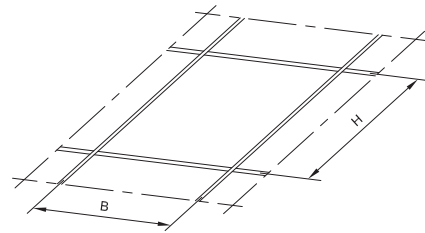

2. Calculation of the load share on the glass support

The load share of the glass weight in vertical glazing is 100%.

The load share of inclined glazing is reduced, depending on the angle.

→ Pane weight [kg] $\times \sin(\alpha)$

Table 8 states the sine value for known inclination angles.

Table 9 states the sine value for known percentage inclination.

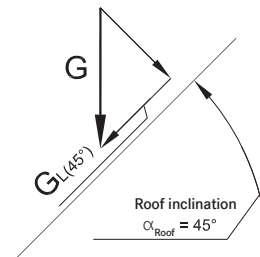

3. Calculation of eccentricity

System H / System AK-H

Symmetrical glass structure

$$e = d + (t_i + SZR + t_m + SZR + t_a)/2$$

Asymmetrical glass structure

$$\begin{aligned} a_1 &= d + t_i/2 \\ a_2 &= d + t_i + SZR_1 + t_m/2 \\ a_3 &= d + t_i + SZR_1 + t_m + SZR_2 + t_a/2 \\ e &= (t_i \times a_1 + t_m \times a_2 + t_a \times a_3)/(t_i + t_m + t_a) \end{aligned}$$

4. Test

Tables 1 - 7 state the permitted pane weight based on the calculated eccentricity "e".

System ZL-H

Symmetrical glass structure

$$e = d + ZL + (t_i + SZR + t_m + SZR + t_a)/2$$

Asymmetrical glass structure

$$\begin{aligned} a_1 &= d + ZL + t_i/2 \\ a_2 &= d + ZL + t_i + SZR_1 + t_m/2 \\ a_3 &= d + ZL + t_i + SZR_1 + t_m + SZR_2 + t_a/2 \\ e &= (t_i \times a_1 + t_m \times a_2 + t_a \times a_3)/(t_i + t_m + t_a) \end{aligned}$$

Note:

Tables 1 - 7 enable calculation of eccentricity for symmetrical glass structures.

Glass supports

9.2
1

Permitted pane weights, depending on the total glass thickness, i.e. the eccentricity “e”

The mullion-transom connections are produced and validated on the building site. The statement of permissible glass weights refers to the “rigid” mullion-transom connections. Deformations from these connections do not lead to any noteworthy sag in the glass supports.

The permissible total weight can be determined using the overall glass thickness t_{Glass} if the glass structure is symmetrical.

The eccentricity column “e” must be used to calculate the permitted total weight if the glass structure is asymmetrical.

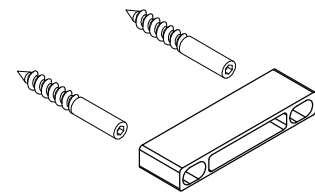

Table 1:
GH 5053 with 2 hanger bolts, System 60 / System 80

Row	Total glass thickness t_{Glass} for single glazing or symmetrical glass structure					Eccentricity “e” mm	Permitted pane weight G (kg)	
	Norden Facade H			Norden Facade ZL-H			VH(NH) Performance class 2 kg	BSH(NH) Performance class 2 kg
	Inner seal height			Inner seal height				
	5 mm	10 mm ¹⁾	12 mm	5 mm	10 mm ²⁾			
1	≤ 20	≤ 10	≤ 6	-	-	15	168	173
2	22	12	8	-	-	16	157	152
3	24	14	10	4	-	17	148	134
4	26	16	12	6	-	18	133	129
5	28	18	14	8	-	19	119	129
6	30	20	16	10	-	20	108	129
7	32	22	18	12	-	21	98	123
8	34	24	20	14	4	22	89	119
9	36	26	22	16	6	23	84	119
10	38	28	24	18	8	24	84	119
11	40	30	26	20	10	25	84	119
12	42	32	28	22	12	26	84	119
13	44	34	30	24	14	27	84	119
14	46	36	32	26	16	28	84	119
15	48	38	34	28	18	29	84	119
16	50	40	36	30	20	30	84	119
17	52	42	38	32	22	31	78	115
18	54	44	40	34	24	32	73	111
19	56	46	42	36	26	33	69	107
20	58	48	44	38	28	34	65	101
21	60	50	46	40	30	35	61	95
22	62	52	48	42	32	36	58	90
23	64	54	50	44	34	37	55	85

¹⁾ Panes must have a total glass thickness of at least 16 mm in inclined glazing

²⁾ Panes must have a total glass thickness of at least 24 mm in inclined glazing

Glass supports

9.2
1

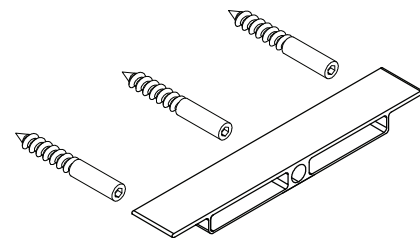

Table 2:
GH 5055 with 3 hanger bolts, System 60 / System 80

Row	Total glass thickness t_{Glass} for single glazing or symmetrical glass structure					Eccentricity "e"	Permitted pane weight G (kg)	
	Norden Facade H			Norden Facade ZL-H			VH(NH) Performance class 2	BSH(NH) Performance class 2
	Inner seal height			Inner seal height				
	5 mm	10 mm ¹⁾	12 mm	5 mm	10 mm ²⁾		kg	kg
1	≤ 20	≤ 10	≤ 6	-	-	15	181	186
2	22	12	8	-	-	16	170	164
3	24	14	10	4	-	17	160	145
4	26	16	12	6	-	18	144	139
5	28	18	14	8	-	19	129	139
6	30	20	16	10	-	20	116	139
7	32	22	18	12	-	21	106	133
8	34	24	20	14	4	22	96	129
9	36	26	22	16	6	23	91	129
10	38	28	24	18	8	24	91	129
11	40	30	26	20	10	25	91	129
12	42	32	28	22	12	26	91	129
13	44	34	30	24	14	27	91	129
14	46	36	32	26	16	28	91	129
15	48	38	34	28	18	29	91	129
16	50	40	36	30	20	30	91	129
17	52	42	38	32	22	31	85	124
18	54	44	40	34	24	32	79	120
19	56	46	42	36	26	33	75	116
20	58	48	44	38	28	34	70	109
21	60	50	46	40	30	35	66	103
22	62	52	48	42	32	36	63	97
23	64	54	50	44	34	37	59	92

¹⁾ Panes must have a total glass thickness of at least 16 mm in inclined glazing

²⁾ Panes must have a total glass thickness of at least 24 mm in inclined glazing

Glass supports

9.2
1

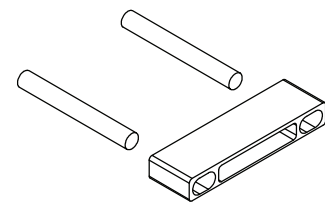

Table 3:
GH 5053 with 2 bolts / hardwood cylinder, System 60 / System 80

Row	Total glass thickness t_{Glass} for single glazing or symmetrical glass structure					Eccentricity "e" mm	Permitted pane weight G (kg)	
	Norden Facade H			Norden Facade ZL-H			VH(NH) Performance class 2 kg	BSH(NH) Performance class 2 kg
	Inner seal height			Inner seal height				
	5 mm	10 mm ¹⁾	12 mm	5 mm	10 mm ¹⁾			
1	≤ 20	≤ 10	-	-	-	15	476	473
2	22	12	8	-	-	16	446	444
3	24	14	10	4	-	17	420	418
4	26	16	12	6	-	18	397	394
5	28	18	14	8	-	19	376	374
6	30	20	16	10	-	20	357	355
7	32	22	18	12	-	21	329	338
8	34	24	20	14	-	22	329	323
9	36	26	22	16	-	23	329	312
10	38	28	24	18	-	24	329	312
11	40	30	26	20	10	25	329	312
12	42	32	28	22	12	26	329	312
13	44	34	30	24	14	27	329	312
14	46	36	32	26	16	28	329	312
15	48	38	34	28	18	29	329	312
16	50	40	36	30	20	30	329	312
17	52	42	38	32	22	31	329	312
18	54	44	40	34	24	32	329	312
19	56	46	42	36	26	33	319	302
20	58	48	44	38	28	34	309	293
21	60	50	46	40	30	35	300	285
22	62	52	48	42	32	36	292	277
23	64	54	50	44	34	37	284	269

¹⁾ Panes must have a total glass thickness of at least 20 mm in inclined glazing

Glass supports

9.2
1

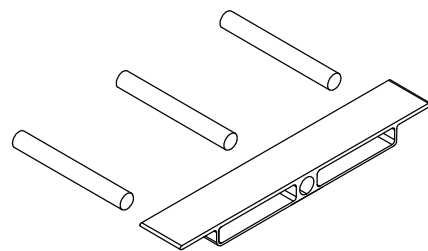

Table 4:
GH 5055 with 3 bolts / hardwood cylinder, System 60 / System 80

Row	Total glass thickness t_{Glass} for single glazing or symmetrical glass structure					Eccentricity "e" mm	Permitted pane weight G (kg)	
	Norden Facade H			Norden Facade ZL-H			VH(NH) Performance class 2 kg	BSH(NH) Performance class 2 kg
	Inner seal height			Inner seal height				
	5 mm	10 mm ¹⁾	12 mm	5 mm	10 mm ¹⁾			
1	≤ 20	≤ 10	-	-	-	15	602	674
2	22	12	8	-	-	16	529	606
3	24	14	10	4	-	17	494	595
4	26	16	12	6	-	18	494	562
5	28	18	14	8	-	19	494	532
6	30	20	16	10	-	20	494	505
7	32	22	18	12	-	21	494	481
8	34	24	20	14	-	22	494	460
9	36	26	22	16	-	23	477	442
10	38	28	24	18	-	24	458	442
11	40	30	26	20	10	25	458	442
12	42	32	28	22	12	26	458	442
13	44	34	30	24	14	27	458	442
14	46	36	32	26	16	28	458	442
15	48	38	34	28	18	29	458	442
16	50	40	36	30	20	30	458	442
17	52	42	38	32	22	31	458	442
18	54	44	40	34	24	32	458	442
19	56	46	42	36	26	33	444	428
20	58	48	44	38	28	34	431	416
21	60	50	46	40	30	35	412	404
22	62	52	48	42	32	36	390	392
23	64	54	50	44	34	37	369	382

¹⁾ Panes must have a total glass thickness of at least 20 mm in inclined glazing

Glass supports

9.2
1

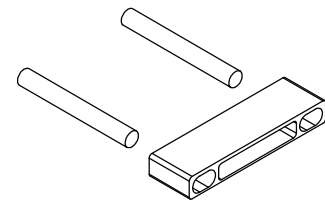

Table 5:
GH 5053 with 2 bolts / hardwood cylinder, System 50

Row	Total glass thickness t_{Glass} for single glazing or symmetrical glass structure					Eccentricity "e"	Permitted pane weight G (kg)	
	Norden Facade H			Norden Facade ZL-H			VH(NH) Performance class 2	BSH(NH) Performance class 2
	Inner seal height			Inner seal height				
	5 mm	10 mm ¹⁾	12 mm	5 mm	10 mm ¹⁾		kg	kg
1	≤ 20	≤ 10	-	-	-	15	500	
2	22	12	8	-	-	16	456	
3	24	14	10	4	-	17	404	
4	26	16	12	6	-	18	360	
5	28	18	14	8	-	19	323	
6	30	20	16	10	-	20	292	
7	32	22	18	12	-	21	283	
8	34	24	20	14	-	22	283	
9	36	26	22	16	-	23	283	
10	38	28	24	18	-	24	283	
11	40	30	26	20	10	25	283	
12	42	32	28	22	12	26	283	
13	44	34	30	24	14	27	283	
14	46	36	32	26	16	28	283	
15	48	38	34	28	18	29	283	
16	50	40	36	30	20	30	283	
17	52	42	38	32	22	31	283	
18	54	44	40	34	24	32	283	
19	56	46	42	36	26	33	266	
20	58	48	44	38	28	34	251	
21	60	50	46	40	30	35	236	
22	62	52	48	42	32	36	223	
23	64	54	50	44	34	37	212	

¹⁾ Panes must have a total glass thickness of at least 20 mm in inclined glazing

Glass supports

9.2
1

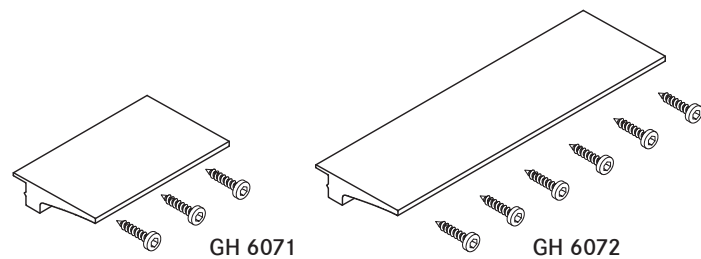

Table 6:
GH 6071 & GH 6072, AK 5010/ AK 6010 screwed on to the timber

Row	Total glass thickness t_{Glass} for single glazing or symmetrical glass structure	Eccentricity e	Permitted pane weight G (kg)			
			AK 5010		AK 6010	
	Inner seal height		Permitted pane weight G (kg)			
			Glass support GH 6071 Width 100 mm	Glass support GH 6072 Width 200 mm	Glass support GH 6071 Width 100 mm	Glass support GH 6072 Width 200 mm
16,5 mm	kg	kg	kg	kg		
1	≤ 24	28,5	487	546	576	1030
2	26	29,5	477	538	572	1001
3	28	30,5	468	529	567	973
4	30	31,5	458	521	563	945
5	32	32,5	449	513	557	917
6	34	33,5	439	505	553	890
7	36	34,5	430	496	548	862
8	38	35,5	420	488	542	834
9	40	36,6	411	480	529	806
10	42	37,5	401	472	513	777
11	44	38,5	392	463	497	751
12	46	39,5	382	455	481	722
13	48	40,5	373	447	465	695
14	50	41,5	363	438	449	667
15	52	42,5	354	430	432	640
16	54	43,5	344	422	413	608
17	56	44,5	335	414	387	553
18	58	45,5	325	405	360	497
19	60	46,5	316	397	333	442

The eccentricity column "e" must be used to calculate the permitted pane weight if the glass structure is asymmetrical.

Glass supports

9.2
1

Table 7:
GH 6073, AK 5010/ AK 6010 screwed on to the timber

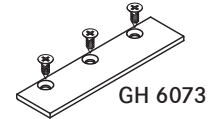

Row	Total glass thickness t_{Glass} for single glazing or symmetrical glass structure	Eccentricity "e"	Permitted pane weight G (kg)	
			AK 5010	AK 6010
	Inner seal height		VH(NH) and BSH(NH) Performance class 2	
	16,5 mm	mm	Glass support GH 6073 Width 100 mm kg	Glass support GH 6073 Width 100 mm kg
1	≤ 18	25,5	510	589

The eccentricity column "e" must be used to calculate the permitted pane weight if the glass structure is asymmetrical.

Glass supports

9.2
1

Table 8:
Sine values

Angle (in °)	Sine	Angle (in °)	Sine	Angle (in °)	Sine	Angle (in °)	Sine	Angle (in °)	Sine
1	0.017	21	0.358	41	0.656	61	0.875	81	0.988
2	0.035	22	0.375	42	0.669	62	0.883	82	0.990
3	0.052	23	0.391	43	0.682	63	0.891	83	0.993
4	0.070	24	0.407	44	0.695	64	0.899	84	0.995
5	0.087	25	0.423	45	0.707	65	0.906	85	0.996
6	0.105	26	0.438	46	0.719	66	0.914	86	0.998
7	0.122	27	0.454	47	0.731	67	0.921	87	0.999
8	0.139	28	0.469	48	0.743	68	0.927	88	0.999
9	0.156	29	0.485	49	0.755	69	0.934	89	1.000
10	0.174	30	0.500	50	0.766	70	0.940	90	1.000
11	0.191	31	0.515	51	0.777	71	0.946		
12	0.208	32	0.530	52	0.788	72	0.951		
13	0.225	33	0.545	53	0.799	73	0.956		
14	0.242	34	0.559	54	0.809	74	0.961		
15	0.259	35	0.574	55	0.819	75	0.966		
16	0.276	36	0.588	56	0.829	76	0.970		
17	0.292	37	0.602	57	0.839	77	0.974		
18	0.309	38	0.616	58	0.848	78	0.978		
19	0.326	39	0.629	59	0.857	79	0.982		
20	0.342	40	0.643	60	0.866	80	0.985		

Table 9:
% inclination relative to the angle in °

%	Inclination (in °)	%	Inclination (in °)	%	Inclination (in °)	%	Inclination (in °)	%	Inclination (in °)
1	0.57	21	11.86	41	22.29	61	31.38	81	39.01
2	1.15	22	12.41	42	22.78	62	31.80	82	39.35
3	1.72	23	12.95	43	23.27	63	32.21	83	39.69
4	2.29	24	13.50	44	23.75	64	32.62	84	40.03
5	2.86	25	14.04	45	24.23	65	33.02	85	40.36
6	3.43	26	14.57	46	24.70	66	33.42	86	40.70
7	4.00	27	15.11	47	25.17	67	33.82	87	41.02
8	4.57	28	15.64	48	25.64	68	34.22	88	41.35
9	5.14	29	16.17	49	26.10	69	34.61	89	41.67
10	5.71	30	16.70	50	26.57	70	34.99	90	41.99
11	6.28	31	17.22	51	27.02	71	35.37	91	42.30
12	6.84	32	17.74	52	27.47	72	35.75	92	42.61
13	7.41	33	18.26	53	27.92	73	36.13	93	42.92
14	7.97	34	18.78	54	28.37	74	36.50	94	43.23
15	8.53	35	19.29	55	28.81	75	36.87	95	43.53
16	9.09	36	19.80	56	29.25	76	37.23	96	43.83
17	9.65	37	20.30	57	29.68	77	37.60	97	44.13
18	10.20	38	20.81	58	30.11	78	37.95	98	44.42
19	10.76	39	21.31	59	30.54	79	38.31	99	44.71
20	11.31	40	21.80	60	30.96	80	38.66	100	45.00

Glass supports

9.2
1

Example for the calculation of vertical glazing with an asymmetrical glass structure

The following examples merely possible uses of the glass supports, without validating the other components used in the system.

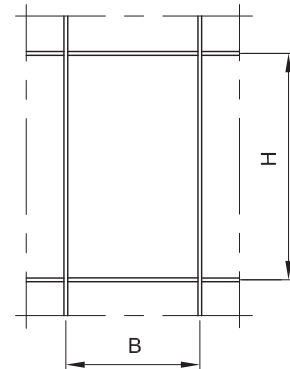

Specifications:

Transom profile: BSH(NH)

Glass pane format: $B \times H = 1.15 \text{ m} \times 2.00 \text{ m} = 2.30 \text{ m}^2$

Glass structure: $t_i / \text{SZR}_1 / t_m / \text{SZR}_2 / t_a = 6 \text{ mm} / 12 \text{ mm} / 6 \text{ mm} / 12 \text{ mm} / 8 \text{ mm}$
 $t_i + t_m + t_a = 20 \text{ mm} = 0.020 \text{ m}$
 $t_{\text{Glass}} = 44 \text{ mm}$

Calculation of the pane weight:

Specific weight of the glass: $\gamma \approx 25.0 \text{ kN/m}^3$

Pane weight: $G = 2.30 \times 25.0 \times 0.020 = 1.15 \text{ kN} \approx 115 \text{ kg}$

Calculation of eccentricity "e":

Height of the inner seal: $d = 5 \text{ mm}$

$a_1 = 5 + 6/2 = 8 \text{ mm}$

$a_2 = 5 + 6 + 12 + 6/2 = 26 \text{ mm}$

$a_3 = 5 + 6 + 12 + 6 + 12 + 8/2 = 45 \text{ mm}$

$e = (6 \times 8 + 6 \times 26 + 8 \times 45)/20 = 28.2 \approx 29 \text{ mm}$

The following options are therefore possible:

based on Table 1, row 15: per. $G \leq 119 \text{ kg} > G \leq 115 \text{ kg}$

GH 5053 with 2 hanger bolts | System H & ZL-H

based on Table 2, row 15: per. $G = 129 \text{ kg} > G = 115 \text{ kg}$

GH 5055 with 3 hanger bolts | System H & ZL-H

based on Table 3, row 15: per. $G = 312 \text{ kg} > G = 115 \text{ kg}$

GH 5053 with 2 bolts/hardwood cylinders | System H & ZL-H

based on Table 4, row 15: per. $G = 442 \text{ kg} > G = 115 \text{ kg}$

GH 5053 with 3 bolts/hardwood cylinders | System H & ZL-H

Glass supports

9.2
1

Example for the calculation of vertical glazing with a symmetrical glass structure

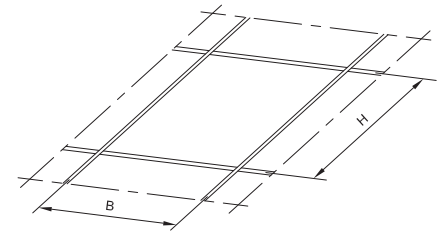

Specifications:

Inclination of the roof surface: $\alpha_{\text{Roof}} = 45^\circ$

Transom profile: System 60; timber VH(NH)

Glass pane format: $W \times H = 2.50 \text{ m} \times 4.00 \text{ m} = 10.00 \text{ m}^2$

Glass structure: $t_i / \text{SZR} / t_a = 12 \text{ mm} / 16 \text{ mm} / 12 \text{ mm}$
 $t_i + t_a = 24 \text{ mm} = 0.024 \text{ m}$
 $t_{\text{Glass}} = 40 \text{ mm}$

Calculation of the pane weight:

Specific weight of the glass: $\gamma \approx 25.0 \text{ kN/m}^3$

Pane weight: $G = 10.00 \times 25.0 \times 0.024 = 6.00 \text{ kN} \approx 600 \text{ kg}$

The roof inclination exerts the following load share on the glass support: $GL(45^\circ) = 600 \times \sin 45^\circ = 424.3 \approx 425 \text{ kg}$

Calculation of eccentricity "e":

Height of the inner seal: $d = 10 \text{ mm}$

$e = 10 + 40/2 = 30 \text{ mm}$

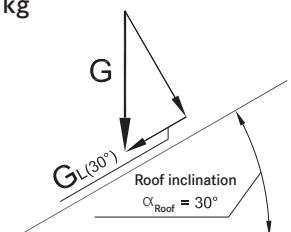

The results confirm the following option:

based on Table 4, row 16: per. $G = 458 \text{ kg} > GL(45^\circ) = 425 \text{ kg}$ GH 5055 with 3 bolts/hardwood cylinders | System H

Transom connector

9.2
2

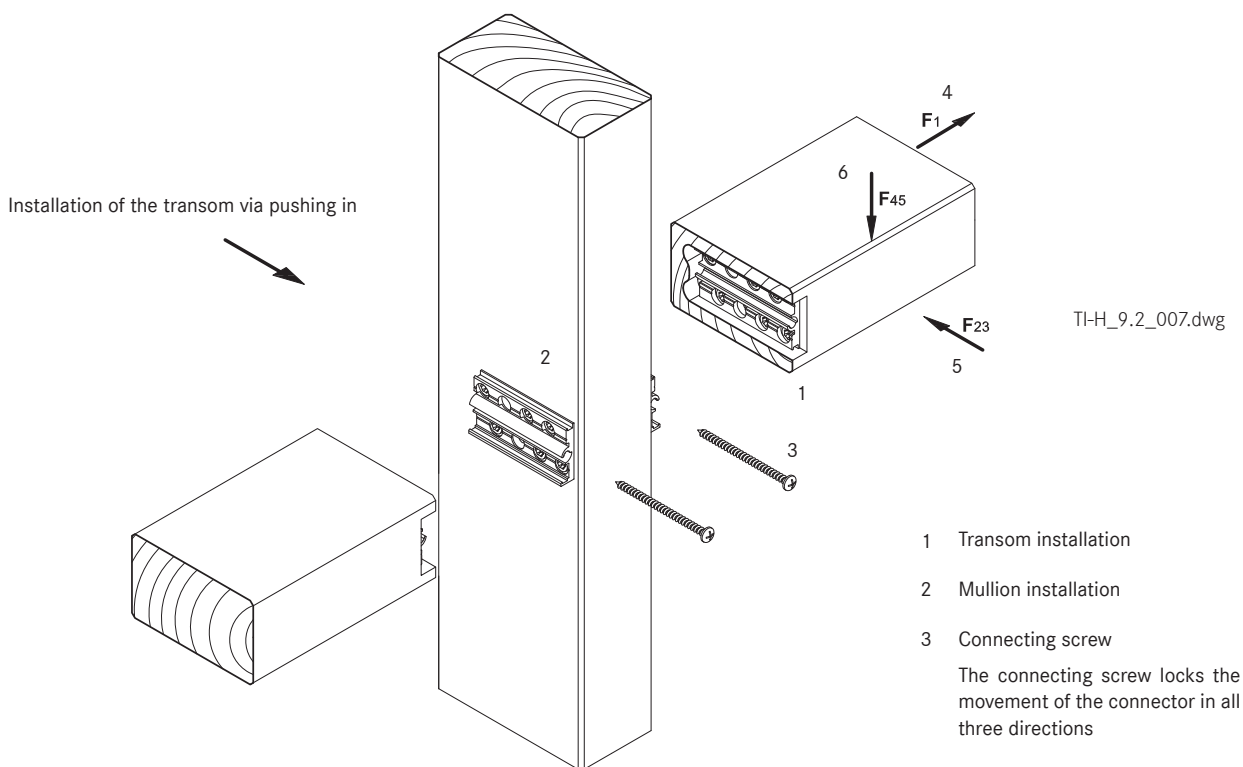

- 4 F_1 = Axial load of the transom
- 5 F_{23} = Windload perpendicular to the curtain wall
- 6 F_{45} = Weight of the glass unit

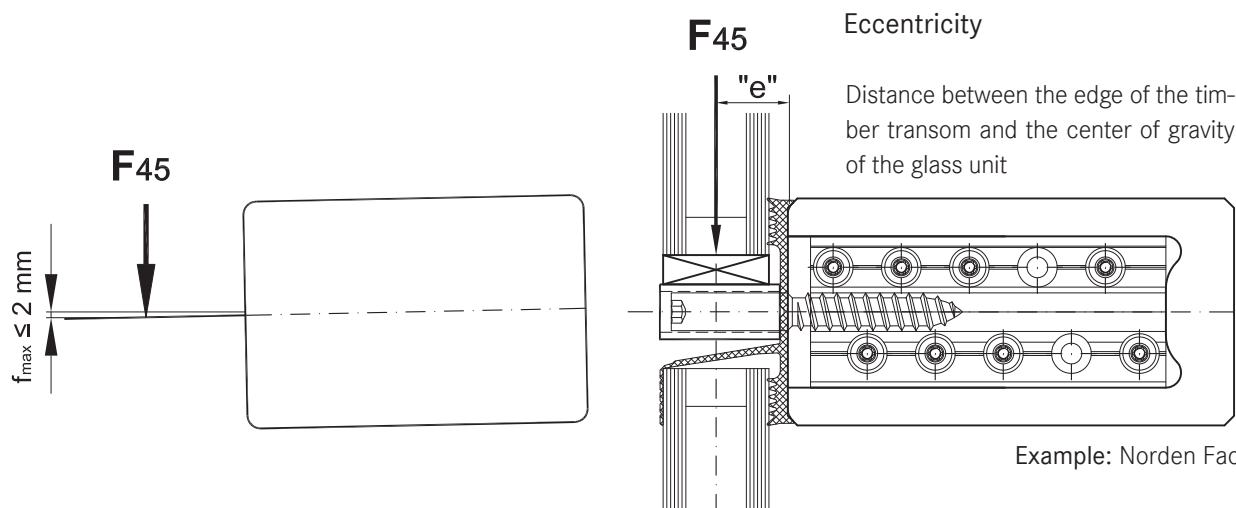

Transom connector

9.2
2

Miscellaneous

The glass supports that Norden Facade supplies are thoroughly tested for load-bearing capacity and fitness for purpose. For this purpose Professor H.J. Blaß from Karlsruhe Institute for Technology was engaged. The tests were carried out at the Karlsruhe Institute for Timber and Building Construction. During the system tests, the load bearing and deformation behavior of the mullion and transom connection was examined for the following load cases:

- Weight of the glass unit (F_{45})
- Windload perpendicular to the curtain wall (F_{23})
- Normal force in the transom (F_1)

Both calculations and tests were carried out as part of the certification. Thanks to the very good correlation between the test results and the calculated values, equations were evaluated for the calculation of the load bearing capacity and fitness for use. These equations are part of the ETA 170165 of March 28, 2017, which serves as the basis for the proof of the load bearing capacity of the mullion-transom connectors.

The measured deflection $f_{\max} = 2 \text{ mm}$ below the theoretical point of application of the resulting weight of the window was used as the limit of usability (transom deflection). The location of the point of application is identified using eccentricity "e".

Eccentricity "e"

The height of the inner seal and the glass structure, i.e. the centre of gravity of the glass pane is determined by the eccentricity "e". The unit "e" describes the distance between the front edge of the timber transom and the theoretical load transfer line.

Allowed glass weight F_{45}

The charts 9-15 show the allowed glass weight in kgs. The loads are per complete transom, with two connectors on both sides. *The load bearing capacities of the glass supports were not taken into account in the tables.*

The permissible glass weights are influenced by the system width, the height of the inner seal, the glass construction / glass thickness and the number of screws (screw variants "V"). *The number of screws in the transom and the mullion has to be equal.*

The calculations include the following coefficients:

k_{mod}	= 0,6	coefficient for permanent load
γ_M	= 1,3	Partial safety coefficient for the properties of the materials
γ_G	= 1,35	Partial safety coefficient for the permanent load

- For the highest possible glass load, as a rule either the limiting condition of the load bearing capacity or the limit state of the usability $f_{\max} = 2 \text{ mm}$ is governing.
- The table values describe the limit state of the bearing capacity with deformation less than $f_{\max} < 2 \text{ mm}$. The limit state of the bearing capacity is therefore decisive.

The determined table values refer to a mullion-transom construction made of solid timber of strength class C24 with a characteristic wood mass density of $\rho_k = 350 \text{ kg/m}^3$. For the application of a different type of wood with a higher strength class and higher wood mass density, the values can be multiplied by factor "R" from the following table:

Timber classes			Mass density ρ_k kg/m ³	Factor R
C24	GL24c		350	1,00
C27			370	1,03
C30	GL28c	GL24h	380	1,04
		GL32c	410	1,09
		GL32h	430	1,12
C50			460	1,16
D30			530	1,27
D40			590	1,36
D50			650	1,44

Transom connector

9.2
2

Table 9:

RHT 8040 Mullion-transom connector for timber for the transom depth 55 - 73 mm

Row	Total glass thickness t_{Glass} for single glazing or symmetrical glass structure					Eccentricity „e“ mm	RHT 8040	
	System and the thickness of the inner gasket						System width 50 / 60 mm	System width 80 mm
	Norden Facade H			ZL-H	AK-H		Screwing option	Screwing option
	5	10	12	15	16,5		V1	V1
	mm	mm	mm	mm	mm	kg	kg	
1	≤24	≤14	≤10			17	62	83
2	26	16	12	≤6		18	61	81
3	28	18	14	8		19	60	80
4	30	20	16	10	≤6	20	59	79
5	32	22	18	12	8	21	58	77
6	34	24	20	14	10	22	57	76
7	36	26	22	16	12	23	56	75
8	38	28	24	18	14	24	55	74
9	40	30	26	20	16	25	54	72
10	42	32	28	22	18	26	54	71
11	44	34	30	24	20	27	53	70
12	46	36	32	26	22	28	52	69
13	48	38	34	28	24	29	51	68
14	50	40	36	30	26	30	50	67
15	52	42	38	32	28	31	50	66
16	54	44	40	34	30	32	49	65
17	56	46	42	36	32	33	48	64
18	58	48	44	38	34	34	48	63
19	60	50	46	40	36	35	47	62
20	62	52	48	42	38	36	46	62
21	64	54	50	44	40	37	46	61
22	66	56	52	46	42	38	45	60
23	68	58	54	48	44	39	44	59
24	70	60	56	50	46	40	44	58
25	72	62	58	52	48	41	43	58
26	74	64	60	54	50	42	43	57
27	76	66	62	56	52	43	42	56
28	78	68	64	58	54	44	42	56
29	80	70	66	60	56	45	41	55
30	82	72	68	62	58	46	41	54
31	84	74	70	64	60	47	40	54

Screwing options:

Values refer to timber mass densities of $\rho_k = 350 \text{ kg/m}^3$

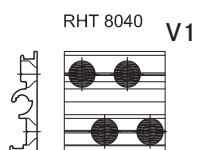

Transom connector

9.2
2

Table 10:

RHT 8058 Mullion-transom connector for timber for the transom depth 74 - 91 mm

Row	Total glass thickness t_{Glass} for single glazing or symmetrical glass structure					Eccentricity „e“ mm	RHT 8058			
	System and the thickness of the inner gasket						System width 50 / 60 mm		System width 80 mm	
	Norden Facade H			ZL-H	AK-H		Screwing option		Screwing option	
	5	10	12	15	16,5		V1	V2	V1	V2
mm	mm	mm	mm	mm	mm	kg	kg	kg	kg	
1	≤24	≤14	≤10			17	70	86	93	114
2	26	16	12	≤6		18	69	84	91	112
3	28	18	14	8		19	68	83	90	110
4	30	20	16	10	≤6	20	67	82	89	109
5	32	22	18	12	8	21	66	81	88	107
6	34	24	20	14	10	22	65	79	86	106
7	36	26	22	16	12	23	64	78	85	104
8	38	28	24	18	14	24	63	77	84	103
9	40	30	26	20	16	25	62	76	83	101
10	42	32	28	22	18	26	62	75	82	100
11	44	34	30	24	20	27	61	74	81	99
12	46	36	32	26	22	28	60	73	80	97
13	48	38	34	28	24	29	59	72	79	96
14	50	40	36	30	26	30	59	71	78	95
15	52	42	38	32	28	31	58	71	77	94
16	54	44	40	34	30	32	57	70	76	93
17	56	46	42	36	32	33	57	69	75	92
18	58	48	44	38	34	34	56	68	74	90
19	60	50	46	40	36	35	55	67	74	89
20	62	52	48	42	38	36	55	66	73	88
21	64	54	50	44	40	37	54	66	72	87
22	66	56	52	46	42	38	54	65	71	86
23	68	58	54	48	44	39	53	64	70	85
24	70	60	56	50	46	40	52	63	70	84
25	72	62	58	52	48	41	52	63	69	83
26	74	64	60	54	50	42	51	62	68	82
27	76	66	62	56	52	43	51	61	68	82
28	78	68	64	58	54	44	50	61	67	81
29	80	70	66	60	56	45	50	60	66	80
30	82	72	68	62	58	46	49	59	65	79
31	84	74	70	64	60	47	49	59	65	78

Screwing options:

Values refer to timber mass densities of $\rho_k = 350 \text{ kg/m}^3$

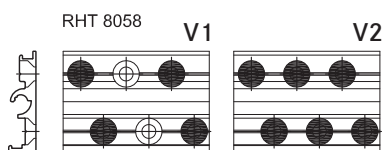

Transom connector

9.2
2

Table 11:

RHT 8076 Mullion-transom connector for timber for the transom depth 92 - 109 mm

Row	Total glass thickness t_{Glass} for single glazing or symmetrical glass structure					Eccentricity „e“ mm	RHT 8076			
	System and the thickness of the inner gasket						System width 50 / 60 mm		System width 80 mm	
	Norden Facade H			ZL-H	AK-H		Screwing option		Screwing option	
	5	10	12	15	16,5		V1	V2	V1	V2
mm	mm	mm	mm	mm	mm	kg	kg	kg	kg	
1	≤24	≤14	≤10			17	105	111	140	147
2	26	16	12	≤6		18	104	109	138	145
3	28	18	14	8		19	102	108	136	144
4	30	20	16	10	≤6	20	101	107	134	142
5	32	22	18	12	8	21	100	105	133	140
6	34	24	20	14	10	22	99	104	131	138
7	36	26	22	16	12	23	98	103	130	137
8	38	28	24	18	14	24	96	102	128	135
9	40	30	26	20	16	25	95	100	127	134
10	42	32	28	22	18	26	94	99	125	132
11	44	34	30	24	20	27	93	98	124	130
12	46	36	32	26	22	28	92	97	123	129
13	48	38	34	28	24	29	91	96	121	128
14	50	40	36	30	26	30	90	95	120	126
15	52	42	38	32	28	31	89	94	119	125
16	54	44	40	34	30	32	88	93	117	123
17	56	46	42	36	32	33	87	92	116	122
18	58	48	44	38	34	34	86	91	115	121
19	60	50	46	40	36	35	85	90	114	120
20	62	52	48	42	38	36	85	89	113	118
21	64	54	50	44	40	37	84	88	111	117
22	66	56	52	46	42	38	83	87	110	116
23	68	58	54	48	44	39	82	86	109	115
24	70	60	56	50	46	40	81	85	108	114
25	72	62	58	52	48	41	80	85	107	113
26	74	64	60	54	50	42	80	84	106	111
27	76	66	62	56	52	43	79	83	105	110
28	78	68	64	58	54	44	78	82	104	109
29	80	70	66	60	56	45	77	81	103	108
30	82	72	68	62	58	46	77	81	102	107
31	84	74	70	64	60	47	76	80	101	106

Screwing options:

Values refer to timber mass densities of $\rho_k = 350 \text{ kg/m}^3$

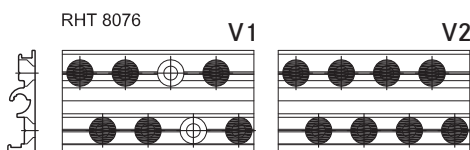

Transom connector

9.2
2

Table 12:

RHT 8094 Mullion-transom connector for timber for the transom depth 110 - 145 mm

Row	Total glass thickness t_{Glass} for single glazing or symmetrical glass structure					Eccentricity „e“ mm	RHT 8094					
	System and the thickness of the inner gasket						System width 50 / 60 mm			System width 80 mm		
	Norden Facade H			ZL-H	AK-H		Screwing option			Screwing option		
	5	10	12	15	16,5		V1	V2	V3	V1	V2	V3
mm	mm	mm	mm	mm	mm	kg	kg	kg	kg	kg	kg	
1	≤24	≤14	≤10			17	124	134	138	165	178	183
2	26	16	12	≤6		18	123	132	136	163	176	181
3	28	18	14	8		19	121	131	135	162	174	179
4	30	20	16	10	≤6	20	120	129	133	160	172	177
5	32	22	18	12	8	21	119	128	132	158	170	175
6	34	24	20	14	10	22	118	126	130	157	168	174
7	36	26	22	16	12	23	117	125	129	155	166	172
8	38	28	24	18	14	24	115	124	128	154	165	170
9	40	30	26	20	16	25	114	122	126	152	163	168
10	42	32	28	22	18	26	113	121	125	151	161	166
11	44	34	30	24	20	27	112	120	124	149	160	165
12	46	36	32	26	22	28	111	119	123	148	158	163
13	48	38	34	28	24	29	110	118	121	146	156	162
14	50	40	36	30	26	30	109	116	120	145	155	160
15	52	42	38	32	28	31	108	115	119	144	153	158
16	54	44	40	34	30	32	107	114	118	142	152	157
17	56	46	42	36	32	33	106	113	117	141	150	155
18	58	48	44	38	34	34	105	112	116	140	149	154
19	60	50	46	40	36	35	104	111	115	138	148	152
20	62	52	48	42	38	36	103	110	114	137	146	151
21	64	54	50	44	40	37	102	109	113	136	145	150
22	66	56	52	46	42	38	101	108	111	135	144	148
23	68	58	54	48	44	39	100	107	110	134	142	147
24	70	60	56	50	46	40	100	106	109	133	141	146
25	72	62	58	52	48	41	99	105	109	131	140	144
26	74	64	60	54	50	42	98	104	108	130	138	143
27	76	66	62	56	52	43	97	103	107	129	137	142
28	78	68	64	58	54	44	96	102	106	128	136	141
29	80	70	66	60	56	45	96	101	105	127	135	139
30	82	72	68	62	58	46	95	101	104	126	134	138
31	84	74	70	64	60	47	94	100	103	125	133	137

Screwing options:

Values refer to timber mass densities of $\rho_k = 350 \text{ kg/m}^3$

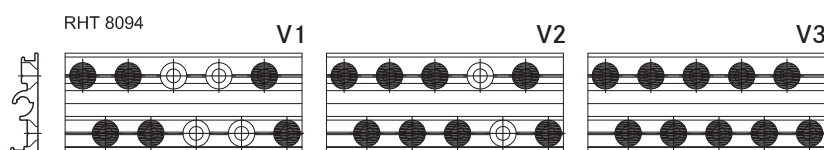

Transom connector

9.2
2

Table 13:

RHT 8130 Mullion-transom connector for timber for the transom depth 146 - 181 mm

Row	Total glass thickness t_{Glass} for single glazing or symmetrical glass structure					Eccentricity „e“ mm	RHT 8130							
	System and the thickness of the inner gasket						System width 50 / 60 mm				System width 80 mm			
	Norden Facade H			ZL-H	AK-H		Screwing option				Screwing option			
	5	10	12	15	16,5		V1	V2	V3	V4	V1	V2	V3	V4
mm	mm	mm	mm	mm	mm	kg	kg	kg	kg	kg	kg	kg	kg	
1	≤24	≤14	≤10			17	154	179	184	195	205	238	245	260
2	26	16	12	≤6		18	153	178	183	193	203	236	243	257
3	28	18	14	8		19	151	176	181	192	201	234	241	255
4	30	20	16	10	≤6	20	150	175	180	190	200	232	239	253
5	32	22	18	12	8	21	149	173	178	188	198	230	237	251
6	34	24	20	14	10	22	148	172	177	187	197	228	235	249
7	36	26	22	16	12	23	147	170	175	185	195	227	233	247
8	38	28	24	18	14	24	146	169	174	184	194	225	231	244
9	40	30	26	20	16	25	145	168	172	182	192	223	229	242
10	42	32	28	22	18	26	143	166	171	181	191	221	228	240
11	44	34	30	24	20	27	142	165	170	179	189	219	226	238
12	46	36	32	26	22	28	141	164	168	178	188	218	224	236
13	48	38	34	28	24	29	140	162	167	176	187	216	222	235
14	50	40	36	30	26	30	139	161	166	175	185	214	221	233
15	52	42	38	32	28	31	138	160	165	174	184	212	219	231
16	54	44	40	34	30	32	137	158	163	172	183	211	217	229
17	56	46	42	36	32	33	136	157	162	171	181	209	216	227
18	58	48	44	38	34	34	135	156	161	170	180	208	214	226
19	60	50	46	40	36	35	135	155	160	168	179	206	213	224
20	62	52	48	42	38	36	134	154	159	167	178	204	211	222
21	64	54	50	44	40	37	133	153	157	166	176	203	209	220
22	66	56	52	46	42	38	132	151	156	164	175	201	208	219
23	68	58	54	48	44	39	131	150	155	163	174	200	206	217
24	70	60	56	50	46	40	130	149	154	162	173	198	205	216
25	72	62	58	52	48	41	129	148	153	161	172	197	204	214
26	74	64	60	54	50	42	128	147	152	160	171	196	202	212
27	76	66	62	56	52	43	127	146	151	159	170	194	201	211
28	78	68	64	58	54	44	127	145	150	157	168	193	199	209
29	80	70	66	60	56	45	126	144	149	156	167	191	198	208
30	82	72	68	62	58	46	125	143	148	155	166	190	197	206
31	84	74	70	64	60	47	124	142	147	154	165	189	195	205

Screwing options:

Values refer to timber mass densities of $\rho_k = 350 \text{ kg/m}^3$

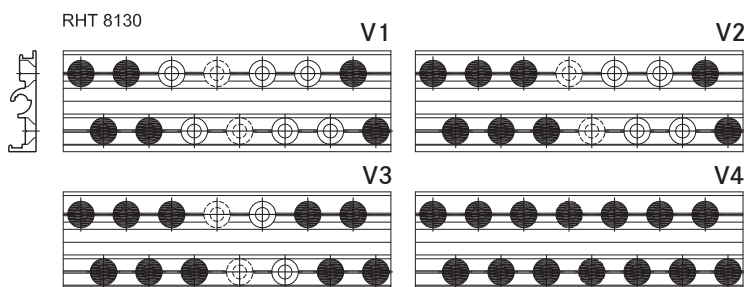

Transom connector

9.2
2

Table 14:

RHT 8166 Mullion-transom connector for timber for the transom depth 182 - 235 mm

Row	Total glass thickness t_{Glass} for single glazing or symmetrical glass structure					Eccentricity „e“ mm	RHT 8166							
	System and the thickness of the inner gasket						System width 50 / 60 mm				System width 80 mm			
	Norden Facade H			ZL-H	AK-H		Screwing option				Screwing option			
	5	10	12	15	16,5		V1	V2	V3	V4	V1	V2	V3	V4
mm	mm	mm	mm	mm	mm	kg	kg	kg	kg	kg	kg	kg	kg	
1	≤24	≤14	≤10			17	174	216	243	255	231	287	324	340
2	26	16	12	≤6		18	173	214	242	253	230	285	321	337
3	28	18	14	8		19	172	213	240	251	228	283	319	334
4	30	20	16	10	≤6	20	171	211	238	250	227	281	317	332
5	32	22	18	12	8	21	170	210	237	248	226	279	315	330
6	34	24	20	14	10	22	169	208	235	246	224	277	312	327
7	36	26	22	16	12	23	167	207	233	244	223	275	310	325
8	38	28	24	18	14	24	166	206	232	243	221	273	308	323
9	40	30	26	20	16	25	165	204	230	241	220	272	306	320
10	42	32	28	22	18	26	165	203	229	239	219	270	304	318
11	44	34	30	24	20	27	164	201	227	238	218	268	302	316
12	46	36	32	26	22	28	163	200	226	236	216	266	300	314
13	48	38	34	28	24	29	162	199	224	234	215	265	298	312
14	50	40	36	30	26	30	161	198	223	233	214	263	296	310
15	52	42	38	32	28	31	160	196	221	231	213	261	294	308
16	54	44	40	34	30	32	159	195	220	230	211	260	293	306
17	56	46	42	36	32	33	158	194	219	228	210	258	291	304
18	58	48	44	38	34	34	157	193	217	227	209	256	289	302
19	60	50	46	40	36	35	156	192	216	225	208	255	287	300
20	62	52	48	42	38	36	155	190	214	224	207	253	285	298
21	64	54	50	44	40	37	154	189	213	222	205	252	283	296
22	66	56	52	46	42	38	154	188	212	221	204	250	282	294
23	68	58	54	48	44	39	153	187	211	220	203	249	280	292
24	70	60	56	50	46	40	152	186	209	218	202	247	278	290
25	72	62	58	52	48	41	151	185	208	217	201	246	277	288
26	74	64	60	54	50	42	150	184	207	216	200	244	275	287
27	76	66	62	56	52	43	149	182	205	214	199	243	273	285
28	78	68	64	58	54	44	149	181	204	213	198	241	272	283
29	80	70	66	60	56	45	148	180	203	212	197	240	270	281
30	82	72	68	62	58	46	147	179	202	210	196	238	269	280
31	84	74	70	64	60	47	146	178	201	209	195	237	267	278

Screwing options:

Values refer to timber mass densities of $\rho_k = 350 \text{ kg/m}^3$

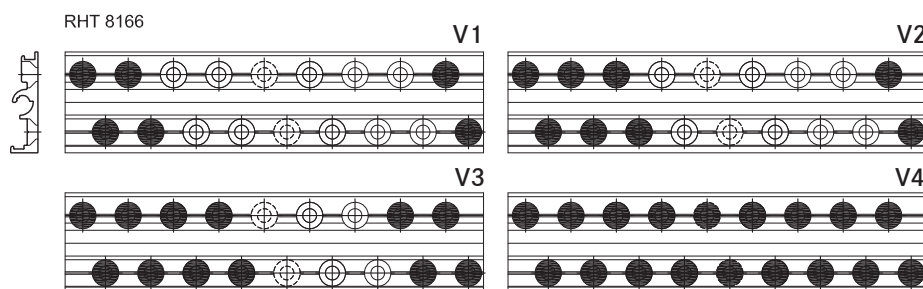

Transom connector

9.2
2

Table 15:

RHT 8220 Mullion-transom connector for timber for the transom depth 236 - 300 mm

Row	Total glass thickness t_{Glass} for single glazing or symmetrical glass structure					Eccentricity „e“ mm	RHT 8220							
	System and the thickness of the inner gasket						System width 50 / 60 mm				System width 80 mm			
	Norden Facade H			ZL-H	AK-H		Screwing option				Screwing option			
	5	10	12	15	16,5		V1	V2	V3	V4	V1	V2	V3	V4
mm	mm	mm	mm	mm	mm	kg	kg	kg	kg	kg	kg	kg	kg	
1	≤24	≤14	≤10			17	254	300	325	348	337	399	432	462
2	26	16	12	≤6		18	252	299	323	346	336	387	429	460
3	28	18	14	8		19	251	297	321	344	334	395	427	457
4	30	20	16	10	≤6	20	250	295	319	342	332	393	424	454
5	32	22	18	12	8	21	248	294	317	340	330	391	422	452
6	34	24	20	14	10	22	247	292	316	338	329	389	420	449
7	36	26	22	16	12	23	246	291	314	336	327	387	417	447
8	38	28	24	18	14	24	245	289	312	334	325	385	415	444
9	40	30	26	20	16	25	243	288	311	332	324	383	413	442
10	42	32	28	22	18	26	242	287	309	330	322	381	411	440
11	44	34	30	24	20	27	241	285	307	328	320	379	409	437
12	46	36	32	26	22	28	240	285	306	327	319	377	406	434
13	48	38	34	28	24	29	239	282	304	325	317	375	404	432
14	50	40	36	30	26	30	237	281	302	323	316	374	402	430
15	52	42	38	32	28	31	236	281	301	321	314	372	400	427
16	54	44	40	34	30	32	235	280	299	320	313	370	398	425
17	56	46	42	36	32	33	234	278	298	318	311	368	396	423
18	58	48	44	38	34	34	233	277	296	316	310	366	394	421
19	60	50	46	40	36	35	232	275	295	315	308	365	392	418
20	62	52	48	42	38	36	231	274	293	313	307	363	390	416
21	64	54	50	44	40	37	229	273	292	311	305	361	388	414
22	66	56	52	46	42	38	228	271	290	310	304	359	386	412
23	68	58	54	48	44	39	227	270	289	308	302	358	384	410
24	70	60	56	50	46	40	226	268	287	307	301	356	382	408
25	72	62	58	52	48	41	225	267	286	305	300	354	380	406
26	74	64	60	54	50	42	224	266	284	303	298	353	378	404
27	76	66	62	56	52	43	223	264	283	302	297	351	376	402
28	78	68	64	58	54	44	222	263	282	300	295	349	375	400
29	80	70	66	60	56	45	221	261	280	299	294	348	373	398
30	82	72	68	62	58	46	220	260	279	297	293	346	371	396
31	84	74	70	64	60	47	219	259	278	296	291	344	369	394

Screwing options:

Values refer to timber mass densities of $\rho_k = 350 \text{ kg/m}^3$

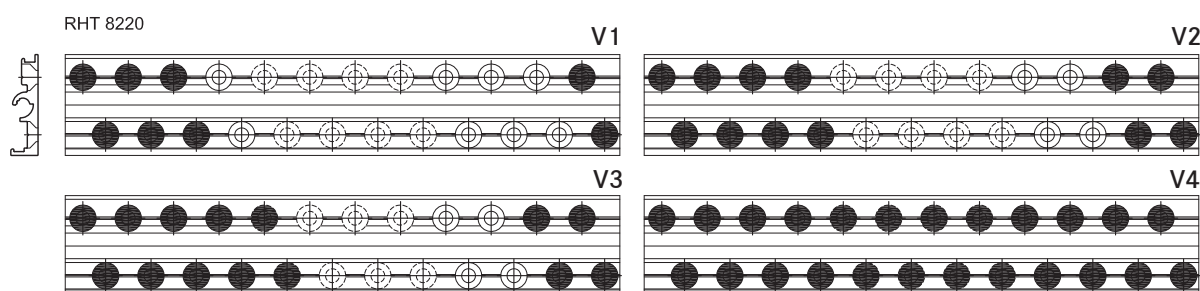

Demand for tested and approved products

9.3
1

Introduction

Principals, planners and processors demand the use of tested and approved products. Construction laws also demand that the building products satisfy the requirements of the Construction Products List (BRL). Glass facades and glass are defined under technical regulations, including for:

- Stability
- Fitness for purpose
- Thermal insulation
- Fire protection
- Sound insulation

These proofs have been provided for Norden Facade facades and roofs. Our production sites and suppliers are quality-certified and guarantee excellent product quality. Moreover, Norden Facade GmbH continuously monitors its products and provides additional validation of the properties and special functions of its facade systems. Prestigious test centres and institutes support the company in its quality assurance.

- Institut für Fenstertechnik, Rosenheim
- Institut für Stahlbau, Leipzig
- Materialprüfungsamt NRW, Dortmund
- Materialprüfanstalt für, Braunschweig
- Materials Testing Institute, University of Stuttgart, Stuttgart
- Beschussamt Ulm
- KIT Steel & Lightweight Structures Research Center for Steel, Timber & Masonry, Karlsruhe
- Institut für Energieberatung, Tübingen
- Institut für Wärmeschutz, Munich
- and many more in Europe and overseas.

























Overview of all tests and approvals

9.3
2

Introduction









The tests we perform help the processor gain access to the market and form the basis for the certifications required by the manufacturer/processor. Their use is only permitted if you have accepted our Terms and Condi-

tions for the Use of Test Reports and Test Certificates. Norden Facade will provide these terms and conditions and other templates on request, e.g. declarations of conformity.

Ift Icon	Requirements according to EN 13830	CE	Info
	Air permeability		See product passport
	Watertightness		See product passport
	Resistance to wind load		See product passport
	Impact resistance if explicitly required in the CE mark		See product passport
	Airborne sound insulation if explicitly required in the CE mark		Refer to Sec. 9
	Heat transition Details for U_{cw} value; from the system provider, in-house calculation of U_i values		on request (refer to Sec. 9)
	Self-weight according to EN 1991-1-1; must be determined by the manufacturer		by static validation (refer to Sec. 9)
	Resistance to horizontal loads The curtain facade must withstand dynamic horizontal loads according to EN 1991-1-1; must be determined by the manufacturer		by static validation
	Water vapour permeability		Validation may be necessary in individual cases
	Durability no test needed		Information on proper maintenance of the facade
	Fire resistance if explicitly required in the CE mark, classification according to EN 13501-2; The European regulations have equal standing and apply in addition to the national regulations (e.g. DIN 4102). Fitness for purpose is still determined based on national regulations. Hence there is no declaration on the CE mark; use general building authorisation as necessary.		
	Fire behaviour if explicitly required in the CE mark Validation for all installed materials according to EN 13501-1		

Overview of all tests and approvals

9.3
2

Ift Icon	Requirements according to EN 13830	CE	Info
	Fire spread if explicitly required in the CE mark Validation in expert assessments		
	Thermal shock resistance if explicitly required in the CE mark Validation by the manufacturer/glass supplier		
	Potential equalisation if specifically required in the CE mark (for metal-based curtain walls when mounted on buildings with a height in excess of 25 m)		
	Seismic safety If specifically required in the CE mark Validation by the manufacturer		
	Building and thermal movement The party organising the tender must specify the building movements, including the movement of the building joints, that the curtain wall will have to carry.		
Ift Icon	Other requirements	CE	Info
	Dynamic driving rain test According to ENV 13050		see product passport
	Proof of fitness for purpose of mechanical connections Clamp connection for attachment Norden Facade timber		Controlled connection or regulated nationally in general building authorisations (abZ); abZ available on request
	Proof of fitness for purpose of mechanical connection T-connection mullion/transom Norden Facade Threaded tube		Controlled connection or regulated nationally in general building authorisations (abZ); abZ available on request
	Burglary-resistant facades Resistance class RC2 according to DIN EN1627		Test reports and expert assessments on request
Ift Icon	Miscellaneous	CE	Info
	Steel profiles for use in indoor swimming pools		
	other statements with tests completed (material testing / stress testing / compatibility testing)		
Ift Icon	Fire resistance requirements / national regulations	CE	Info
	Fire protection facade Norden Facade System H (timber with central groove) → G30 / F30		regulated nationally in general building authorisations (abZ); abZ available on request

Overview of all tests and approvals

9.3
2

Example of a declaration of conformity for fire protection glazing abZ 19.14-xxxx

Declaration of conformity	
- Name and address of the company that produced the fire protection glazing (object of the approval):	

- Building site, i.e. building:	

- Date of production:	_____
- Required fire resistance class for the fire protection glazing:	_____ F30 _____
This is to confirm that	
- the fire protection glazing and all of its components were manufactured, installed and labelled professionally and with adherence to all provisions of the general building authorisation no.: Z-19.14-xxxx by DIBt dated _____ (and any provisions contained in the notifications of changes and additions dated _____), and	
- that construction products used for the manufacture of the object of this authorisation (e.g. frames, panes) satisfy the provisions of this general building authorisation and are labelled as required. This applies equally to parts of the object of this approval for which the authorisation may have imposed conditions.	
_____	_____
(Place, date)	(Company / signature)
(This certification must be submitted to the principal for forwarding to the competent construction supervision authorities as required.)	

Construction Products Regulation (BauPV)

Regulation (EU) No 305/2011 regarding the harmonisation of construction products was introduced on 1 July 2013, replacing Regulation No 89/106/EEC, which had applied until then.

Regulation 305/2011 defines the terms under which construction products may be “placed on the market” in all European member states. Its ratification in national law is therefore not necessary. The purpose of Regulation 305/2011 is to ensure the safety of structures for humans, animals and the environment. The harmonised standard provides precise definitions of essential performance characteristics, as well as product and test standards for construction products. This ensures largely comparable performance characteristics throughout Europe.

The harmonised standard EN 13830 applies to curtain walls.

Regulation No 89/106 was mainly used to demonstrate to customers that a product conformed to the harmonised European standard. In contrast, Regulation No 305/2011 demands the issue of a Declaration of Performance, which the manufacturer must submit to the customer as assurance of the essential performance characteristics.

Besides the declaration of performance, Regulation No 305/2011 continues to demand, in line with Regulation No 89/106:

- an initial type test (ITT) of the products
- a factory production control (FPC) by the manufacturer
- a CE mark

Declaration of Performance

The declaration of performance (LE, i.e. DoP = Dec^laration of Performance) under Regulation No 305/2011 replaces the declaration of conformity used until now according to Regulation No 89/106. It is the central document with which the manufacturer of the curtain wall accepts responsibility and provides assurances for the conformity of declared performances.

The manufacturer must use this declaration of performance to obtain CE labelling for the facade before it is entitled to place the construction product on the market. The CE mark confirms that a declaration of performance exists. Described properties of the curtain wall are stated in both of these documents, the declaration of performance and the CE mark. The declaration of performance and the CE mark must be unequivocally associated.

Only the manufacturer of the facade is entitled to submit the declaration of performance.

At least one essential characteristic must be stated in the declaration of performance. A dash is added to the corresponding field if one essential characteristic does not apply, but is defined by a limit value. The entry “**npd**” (**n**o **p**erformance **d**etermined) is not permitted in these cases.

It is advisable to state the performances as listed in the property’s individual requirement specifications.

A declaration of performance under Regulation No 305/2011 can only be issued once the product has been manufactured, and not during the bidding phase. The declaration of performance must be presented in the language of the member state to which the construction product will be delivered.

The declaration of performance is handed over to the customer.

Declarations of performance must be archived for at least **10 years**.

The requirements placed in curtain walls are defined in the harmonised standard EN 13830. All performances relating to the characteristics addressed in this standard must be determined if the manufacturer intends their declaration. This does not apply if the standard contains instructions for the statement of performances without testing (e.g. for the use of existing data, for classification without further testing and for the use of generally acknowledged performance values).

BauPV / DOP / ITT / FPC / CE

9.3
3

Manufacturers are entitled to group their products as families for the purpose of assessment. But this applies only if the findings in regard to one or more characteristic/s of a given product within a family can be considered representative of the same characteristic/s of all products within the same family. Hence, the essential characteristics can be determined using representative test specimens in what is known as the (ITT = Initial Type Test); this is then used as a reference base.

Insofar as the manufacturer procures construction products from a system provider (often called the system distributor), and provided this entity has suitable legal authorisation, the system provider may accept responsibility for the determination of the product type in regard to one or several essential characteristics of an end product that is subsequently manufactured and/or assembled by the processors in their plants. This is predicated on an agreement between the parties. This agreement may be a contract, a license or any other form of written accord that provides an unequivocal assignment of the component manufacturer's responsibility and liability (the system distributor on the one hand, and the company assembling the end product on the other). In this case, the system distributor must subject the "assembled product", consisting of components that it or another party has manufactured, to a determination of product type and must thereafter present the test report to the manufacturer of the product that is actually placed on the market.

The findings of the determination of product type must be documented in test reports. The manufacturer must keep all test reports for at least 10 years following the data of final manufacture of the curtain wall kit to which the report refers.

[Initial Type Test = ITT]

An initial type test (ITT) involves the determination of product characteristics according to the European product standard for curtain walls, EN 13830. The initial type test can be performed on representative test specimens by means of measurement, calculation or another method described in the product standard. It is usually acceptable in this respect to perform the initial type test

on a representative element of the product family to determine one or more performance characteristics. The manufacturer must commission accredited test institutes to conduct initial type tests. The details are defined in the product standard EN 13830. Any deviations from the tested element are the responsibility of the manufacturer and must not lead to a deterioration of the performance characteristics.

The European Commission allows the system providers to perform this initial type test on their own systems as a service, and to submit the findings to their customers for use in the declaration of performance and in the CE mark.

Initial type tests have been performed on the individual Norden Facade systems to determine the product characteristics.

The manufacturer (e.g. metal worker) is entitled, under certain conditions (e.g. use of the same components, incorporation of the processing guidelines in the factory production control, etc.), to use the initial type test made available by the system provider.

The following conditions are defined for the submission of test certificates to the processor:

- The product is manufactured using the same components with identical characteristics as the test specimen presented in the initial type test.
- The processor carries the full responsibility for conformity with the system provider's processing guidelines and for the correct manufacture of the construction product placed on the market.
- The system provider's processing guidelines are integral elements of the factory production control applied by the processor (manufacturer).
- The manufacturer is in possession of the test reports with which it carries out CE marking of its products, and is entitled to use these reports.
- The manufacturer must commission a notified body with the testing insofar as the tested product is not representative of the product that is placed on the market.

The processor may only use the test certificates if it has entered into an agreement with the system provider, in which the processor undertakes to use the elements in

BauPV / DOP / ITT / FPC / CE

9.3
3

accordance with the processing instructions and only in connection with the articles defined by the system provider (e.g. material, geometry).

Factory production control

[Factory Production Control = FPC]

The manufacturer/processor is obliged to establish a system of factory production control (FPC) in its plants in order to ensure that the identified performance characteristics stated in the test reports in reference to the products are adhered to.

It must install operating procedures and work instructions that systematically define all data, requirements and regulations that concern the products. Moreover, a responsible person must be appointed for the production facility, and this person must be suitably qualified to check and confirm the conformity of the manufactured products.

The manufacturer/processor must provide suitable test equipment and/or devices for this purpose.

The manufacturer/processor must perform the following steps in the factory production control (FPC) for curtain walls (without fire and smoke resistance requirements) in accordance with EN 13830:

Establishment of a documented production control system that is suitable for the product type and the production conditions

- Review that all necessary technical documents and processing instructions are available
- Definition and validation of raw materials and components
- In-process control and examinations in the frequency defined by the manufacturer
- Review and examinations of finished products/components in the frequency defined by the manufacturer
- Description of measures to be undertaken in the event of non-conformity (corrective measures)

The results of the factory production control (FPC) must be documented, assessed and archived, and

must contain the following data:

- Product designation (e.g. construction project, precise specification of the curtain facade)
- Documents or references to technical records and processing guidelines as required
- Test methods (e.g. statement of the work stages and test criteria, documents and samples)
- Test findings and comparison with the requirements as necessary
- Measures to be undertaken in the event of non-conformity as necessary
- Date of product completion and date of product testing
- Signature of the investigator and the person responsible for factory production control

The records must be kept for a period of 5 years.

The following applies to companies certified according to DIN EN ISO 9001: this standard will only be recognised as an FPC system if it is adjusted to satisfy the requirements of the product standard EN 13830.

CE mark

A CE mark may only be awarded if there is a declaration of performance. The CE mark may only list performances that were also declared in the declaration of performance. Any characteristics declared as “npd” or “–” in the declaration of performance must not be listed on the CE mark.

The product standard does not require that all components of the curtain wall are designated and marked individually. The CE mark must be easily legible, of a sufficient size and attached to the facade permanently. Alternatively, the mark can be attached to the accompanying documents.

Only the manufacturer of the facade is entitled to issue the CE mark.

Note:

The statements above only apply to glazing without fire-resistance properties.

The manufacturer must submit an EU Declaration of Conformity issued by an external certification body for fire-resistant glazing.

BauPV / DOP / ITT / FPC / CE

9.3
3

CE mark template

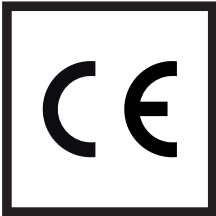
		CE mark, comprising the "CE" logo
Facade Construction John Doe John Doe Street 1 12345 John Doe City		Name and registered address of the manufacturer or logo (DoP item 4)
13		The last two numerals of the year in which the mark was first attached
Germany		
Norden Facade system		Product's clear identification code (DoP item 1)
LE/DoP no.: 001 /CPR/01.07.2013		Reference number of the declaration of performance
EN 13830		Number of the applied European standard as stated in the EU Official Journal (DoP item 7)
Assembly set for curtain facades for use outdoors		Intended purpose of the product as stated in the European standard (DoP item 3)
Fire behaviour	npd	Level or class of stated performance (Do not declare higher performance characteristics than required in the specifications!) (DoP item 9)
Fire resistance	npd	
Fire spread	npd	
Watertightness	RE 1650 Pa	
Resistance to self-weight	000kN	
Resistance to wind load	2.0 kN/m ²	
Impact resistance	E5/I5	
Thermal shock resistance	ESG	
Resistance to horizontal loads	000kN	
Air permeability	AE	
Heat transfer coefficient	0.0 W/(m ² K)	
Airborne sound insulation	0.0 dB	
First tests conducted and classification reports prepared by: ift Rosenheim NB no. 0757		Identification number of the certified test laboratory (DoP item 8)

BauPV / DOP / ITT / FPC / CE

9.3
3

Declaration of performance template

a Declaration of Performance		
LE/DoP no.: 021/CPR/01.07.2013		
1.	Product's identification code:	Norden Facade system
2.		from the manufacturer
3.	Intended purpose:	Assembly set for curtain facades for use outdoors
4.	Manufacturer	Facade Construction John Doe John Doe Street 1 12345 John Doe City
5.	Authorised person:	./.
6.	System or system requiring assessment of constancy of performance:	3
7.	Harmonised standard:	EN 13830:2003
8.	Notified body:	Ift Rosenheim NB no. 0757 conducted the first tests as notified test laboratory in conformity system 3 and thereupon issued the test and classification reports.
9.	Essential characteristics:	
	Essential characteristic: (Section EN 13830)	Performance
		Harmonised technical specification
9.1	Fire behaviour (Sec. 4.9)	npd
9.2	Fire resistance (Sec. 4.8)	npd
9.3	Spread of fire (Sec. 4.10)	npd
9.4	Driving rain resistance (Sec. 4.5)	RE 1650 Pa
9.5	Resistance to self-weight (Sec. 4.2)	npd
9.6	Resistance to wind load (Sec. 4.1)	2.0 kN/m ²
9.7	Impact resistance	E5/I5
9.8	Thermal shock resistance	npd
9.9	Resistance to horizontal loads	npd
9.10	Air permeability	AE
9.11	Heat transition	$U_f \leq 0.0 \text{ W/m}^2\text{K}$
9.12	Airborne sound insulation	0.0 dB
10.	The performance of the product according to Numbers 1 and 2 corresponds to the declared performance according to Number 9.	

Exclusively the manufacturer according to number 4 is responsible for preparing the Declaration of Performance.
Signed for and on behalf of the manufacturer by:

John Doe City, 01/07/2013

ppa. Joh Doe, Management

DIN EN 13830 / Explanations

9.3
4

Definition of a curtain wall

EN 13830 defines the “curtain wall” to mean:

“[...] usually consists of vertical and horizontal structural members, connected together and anchored to the supporting structure of the building and infilled, to form a lightweight, space enclosing continuous skin, which provides, by itself or in conjunction with the building construction, all the normal functions of an external wall, but does not take on any of the load bearing characteristics of the building structure.”

The standard applies to curtain facades that are parallel to the vertical structure of the building surface, to those that deviate from the vertical by up to 15°. Inclined glazing elements included in the curtain facade may be enclosed.

Curtain facades (mullion-transom constructions) are comprised of a number of components and/or pre-fab units that are not assembled to create a finished product until they reach the building site.

Properties, i.e. controlled characteristics in EN 13830

The purpose of the CE mark is to ensure adherence to basic safety requirements placed in the facade and to enable free traffic of goods in Europe. The product standard EN 13830 defines and regulates the essential characteristics of these basic safety requirements as mandated properties:

- Resistance to wind load
- Self-weight
- Impact resistance
- Air permeability
- Watertightness
- Airborne sound insulation
- Heat transition
- Fire resistance
- Fire behaviour
- Fire spread
- Durability
- Water vapour permeability

- Potential equalisation
- Seismic safety
- Thermal shock resistance
- Building and thermal movement
- Resistance to dynamic horizontal loads

So-called initial type testing must be performed in order to validate the essential characteristics. They are performed either by the notified body (e.g. ift Rosenheim) or by the manufacturer (processor), depending on the specific characteristic type. Other requirements may apply to characteristics in specific properties, which then must be validated also.

The method applied to perform the testing and the type of classification are defined in product standard EN 13830, which makes frequent references to European standards. In some case the product standard itself defines the test methods.

The characteristics and their significance

The requirements are defined in the product standard DIN EN 13830. The following contains excerpts or summaries.

The excerpts are taken from the German version of the currently valid standard, DIN EN 13830-2003-11. The draft standard prEN 13830 was published in its German version in June 2013. Besides editing, the document was revised thoroughly from a technical perspective as well, which means that the following passages will need to be checked and may require revision once the standard has been introduced.

Resistance to wind load

“Curtain walls must be sufficiently stable to withstand the positive and negative wind loads applied during a test according to DIN E 12179 and upon which planning for the fitness for purpose is based. They must safely transmit the wind loads underlying the planning to the building structure by way of the fastening elements installed for this purpose. The wind loads underlying the planning are stated in the test according to EN 12179.

During exposure to the wind loads underlying the plan-

DIN EN 13830 / Explanations

9.3
4

ning, the maximum frontal deflection of the individual parts of the curtain wall frame between the support, i.e. anchor points, must not exceed $L/200$, i.e. 15, during a measurement according to EN 13116, depending on which is the smaller value.”

The rated value for the CE mark is expressed in the unit [kN/m²].

We would like to point out that static validation for the specific property must be provided for each curtain wall system, regardless of the initial type testing.

It is also important to point out that the new draft standard intends to introduce an entirely new provision in regard to fitness for purpose, which will affect the dimensioning of the mullion-transom construction significantly.

$f \leq L/200;$	if $L \leq 3000$ mm
$f \leq 5$ mm + $L/300;$	if 3000 mm < $L < 7500$ mm
$f \leq L/250;$	if $L \geq 7500$ mm

This change in deformation limitation means that there may be different limits applicable to an infill (e.g. glass, composite insulation, etc.) and greater utilisation of the profile in terms of loadbearing capacity.

Self-weight

“Curtain walls must carry their own weight and all other connected pieces included in the original planning. They must safely transmit the weight to the building structure by way of the fastening elements installed for this purpose.

Self-weight must be determined according to EN 1991-1-1.

The maximum deflection of any horizontal primary beam due to vertical loads must not exceed $L/500$, i.e. 3 mm, depending on which is the smaller value.”

The rated value for the CE mark is expressed in the unit [kN/m²].

We would like to point out that static validation for the specific property must be provided for each curtain wall system, regardless of the initial type testing.

The 3mm limit is deleted from the draft standard. It is nevertheless necessary to guarantee that any contact between the frame and the infill element is prevented in order to provide sufficient ventilation as necessary. Moreover, the required inset depth of the infill must also be guaranteed.

Impact resistance

“If demanded explicitly, tests must be performed according to EN 12600:2002, Part 5. The findings must be classified according to prEN 14019. The glass products must correspond to EN 12600.”

The impact resistance class is determined internally and externally for the CE mark. The head in [mm] of the pendulum is used to define the class (e.g. class I4 for internal, class E4 for external).

A pendulum is caused to impact with critical points of the facade construction (central mullion, central transom, intersection between mullion/transom, etc.) from a certain height for the purpose of this test. Permanent deformation of the facade is permitted. But falling parts, holes or cracks are prohibited.

Air permeability

“Air permeability must be tested according to DIN EN 12153. The findings must be presented according to EN 12152.”

The air permeability class is determined using the test pressure in [Pa] for the CE mark (e.g. class A4).

Watertightness

“Watertightness must be tested according to DIN EN 12155. The findings must be presented according to EN 12154.”

The watertightness class is determined using the test pressure in [Pa] for the CE mark (e.g. class R7).

DIN EN 13830 / Explanations

9.3
4

Airborne sound insulation $R_w(C; C_{tr})$

“If demanded explicitly, the sound insulation level must be determined according to EN ISO 140-3. The findings must be presented according to EN ISO 717-1.”

The rated value for the CE mark is expressed in the unit [dB].

Validation must be provided for each property.

Heat transmittance U_{cw}

“The method of assessing/calculating the heat transmittance of curtain walls and the suitable test methods are defined in prEN 12631 - 01.2013.”

The rated value for the CE mark is expressed in the unit [W/(m²·K)].

The U_{cw} value is dependent on the heat transfer coefficient U_f of the frame (mullion-transom construction of the facade) on the one hand, and on the heat transfer coefficient of the inset elements, for instance glass and its U_g value, on the other. Other factors also contribute, e.g. the edge bonding of the glass, etc., and the geometry (axis dimensions, number of mullions and transoms in the facade construction). The manufacturer/processor must validate the heat transfer coefficient U_{cw} in calculations or measurements. The system provider can also be requested to submit in-house calculations of the U_f values.

Validation must be provided for each property.

Fire resistance

“If demanded explicitly, the proof of fire resistance according to prEN 13501-2 must be classified.”

The class of fire resistance for the CE mark is determined according to the function (E = integrity; EI = integrity and insulation), the direction of fire and the duration of fire resistance in [min] (e.g. class EI 60, i ↔ o).

However, there is no harmonised standard currently available, and it is therefore not possible to make a declaration in the CE mark (“npd“ = no performance determined).

The national system of “general building authorisation for fire resistance glazing” will therefore remain in this case, although it is not declared in the CE mark.

Fire spread

“If demanded explicitly, the curtain wall must include suitable devices that inhibit the spread of fire and smoke through openings in the curtain wall construction by means of the installation of structural base plates on the connections in all levels.”

Validation must be provided for each property, for instance in the form of an expert assessment.

Durability

“The permanence and performance characteristics of the curtain wall are not tested; instead the testing refers to the level of correspondence between the materials and surfaces with what is considered state-of-the-art, or with European specifications for the materials or surfaces, insofar as they have been published.”

The user must maintain and service the individual components of the facade in response to the natural ageing process. The manufacturer/processor must provide the user with suitable instructions for professional implementation (e.g., the facade should be cleaned regularly in order to safeguard its designated service life, etc.). It appears sensible in this respect for the manufacturer and user to conclude a maintenance contract.

Product instructions or relevant leaflets, e.g. published by VFF, must be observed in this respect.

Water vapour permeability

“Vapour barriers according to the relevant European standards must be included in order to control the defined and ascertained hydrothermal conditions in the building.”

Validation must be provided for each property. There is no specific description of performance for this feature; hence, no accompanying information on the CE mark is necessary.

DIN EN 13830 / Explanations

9.3
4

Potential equalisation

“Watertightness must be tested according to DIN EN 12155. The findings must be presented according to EN 12154.”

Validation must be provided for each property; it is declared in SI units [Ω].

Seismic safety

“If necessary in the specific case, the seismic safety must be determined according to the Technical Specifications or other requirements defined for the location of use.”

Validation must be provided for each property.

Thermal shock resistance

“A suitable glass, e.g. hardened or pre-tensioned glass according to European standards, must be used insofar as the glass is required to exhibit resilience to temperature fluctuation.”

Validation must be provided for each property and refers exclusively to the glass installed in the property.

Building and thermal movement

“The design of the curtain wall must be capable of absorbing thermal movements and movements of the structure in such a way that destruction of facade elements or impairment of the performance characteristics do not occur. The party organising the tender must specify the building movements, including the movement of the building joints, that the curtain wall will have to carry.”

Validation must be provided for each property.

Resistance to dynamic horizontal loads

The curtain wall must withstand dynamic horizontal loads at the level of the sillpiece according to EN 1991-1-1.”

Validation must be provided for each property, and can be verified by way of static validation produced by calculation. It is important to consider in this respect that the height of the sillpiece will vary under national regulations. The value is expressed in [kN] at height (H in [m]) of the sillpiece.

DIN EN 13830 / Explanations

Classification matrix

The following table contains the classification of characteristics for curtain walls according to EN 13830, Part 6:

Note

It is not necessary to determine the performance of a component if this performance is irrelevant to its use. In this respect, the manufacturer/processor merely adds “npd – no performance determined” in the accompanying papers; alternatively, the characteristics can also be omitted. This option does not apply to limit values.

The classification of characteristics for the curtain wall according to the aforementioned specifications must take place for each structure individually, irrespective of whether the system is standard or was produced specifically for the project.

No.	Ift Icon	Designation	Units	Class or rated value						
1		Resistance to wind load	kN/m ²	npd	Rated value					
2		Self-weight	kN/m ²	npd	Rated value					
3		Impact resistance Inside with head in mm	(mm)	npd	I0	I1	I2	I3	I4	I5
					-	200	300	450	700	950
4		Impact resistance Outside with head in mm	(mm)	npd	E0	E1	E2	E3	E4	E5
					-	200	300	450	700	950
5		Air permeability with test pressure Pa	(Pa)	npd	A1	A2	A3	A4	AE	
					150	300	450	600	> 600	
6		Watertightness with test pressure Pa	(Pa)	npd	R4	R5	R6	R7	RE	
					150	300	450	600	> 600	
7		Airborne sound insulation R _w (C; C _{tr})	dB	npd	Rated value					
8		Heat transition U _{cw}	W / m ² k	npd	Rated value					
9		Fire resistance Integrity (E)	(min)	npd	E	E	E	E		
					15	30	60	90		
10		Integrity and insulation (EI)	(min)	npd	EI	EI	EI	EI		
					15	30	60	90		
11		Potential equalisation	Ω	npd	Rated value					
12		Resistance to lateral wind load	kN at m height of the parapet bar	npd	Rated value					

Introduction

9.4
1

Miscellaneous

The facade is an interface between inside and outside. It is frequently compared with the human skin that possesses the ability to respond spontaneously to external influences. A facade works in a similar way: it guarantees a comfortable environment for users inside the building, while positively influencing the building's energy management. The climatic conditions are crucial in this respect. The selection and design of a facade is therefore strongly dependent on its geographic location.

A planned facade must satisfy minimum heat insulation requirements according to the generally acknowledged rules of engineering if it is to be erected in line with the Energy Saving Ordinance (EnEV) and DIN 4108 Thermal insulation and energy economy in buildings. This is because heat insulation affects the building and its users:

- the health of its users, e.g. by providing a hygienic atmosphere
- protection of the structural integrity against the climate-related effects of humidity and its follow-on damage
- energy consumption for heating and cooling
- and therefore the costs and climate protection

Particularly strict requirements are defined for heat insulation installed on facades in today's age of climate change. As a rule: A building will consume less energy and will therefore cause less environmental pollution due to CO₂ emissions if it possesses better structural heat insulation.

The entire facade and all of its components must be optimised in order to achieve ideal heat insulation, with low heat losses in winter and a salubrious room climate in the summer. This involves, for example, the use of suitable materials to reduce heat transmittance, the mounting of heat-insulated frame constructions or the installation of insulating glass. Important criteria in the planning phase therefore include the overall energy transmittance of glazing, depending on the size and orientation of the windows, the heat storage capacity of individual components and sun protection measures.

Norden Facade timber facades offer outstanding U_f values. The certificate 'Mullion and transom facade components to passive house standard' was issued for the Norden Facade H system widths 50 and 60 mm.

Standards

9.4
2

Index of applicable standards and regulations

EnEV	Ordinance for energy-saving thermal insulation and energy-saving systems in buildings (Energy Saving Ordinance EnEV) dated 01.10.2009.
DIN 4108-2:	2001-07, Thermal protection and energy economy in buildings - Part 2: Minimum requirements to thermal insulation
DIN 4108-3:	2001-07, Thermal protection and energy economy in buildings - Part 3: Protection against moisture subject to climate conditions; Requirements and directions for design and construction
DIN 4108	Annex 2:2006-03, Thermal insulation and energy economy in buildings - Thermal bridges - Examples for planning and performance
DIN V 4108-4:	2007,06, Thermal protection and energy economy in buildings - Protection against heat and moisture, technical parameters
DIN EN ISO 10077-1:	2010-05, Thermal performance of windows, doors and shutters - Calculation of thermal transmittance - Part 1: Miscellaneous
DIN EN ISO 10077-2:	2012-06, Thermal performance of windows, doors and shutters - Calculation of thermal transmittance - Part 2: Numerical methods for frames
DIN EN ISO	2007-07, Thermal performance of curtain walls, determination of the 12631 - 01.2013: thermal transmittance coefficient U_{cw}
DIN EN 673:	2011-04, Glass in building - Determination of thermal transmittance U_g
DIN EN ISO 10211-1:	2008-04, Thermal bridges in building construction - Heat flows and surface temperatures - Part 1: Detailed calculations (ISO 10211_2007); German version of EN ISO 10211:2007
DIN EN ISO 6946:	2008-04, Thermal resistance and thermal transmittance - Calculation method
DIN 18516-1:	2010-06, Cladding for external walls, ventilated at rear - Part 1: Requirements, principles of testing

Basis of the calculation

9.4
3

Definitions:

U - The heat transfer coefficient

(also known as the thermal insulation value, U value, previously the k value) is a unit describing the transmittance of thermal energy through a single or multi-layer material when different temperatures prevail on either side. It states the power (so the volume of energy per time unit) that passes through a surface of 1 m² if the stationary air temperature on both sides differs by 1 K. Its SI unit is therefore:

W/(m²·K) (watts per square metre and kelvin).

The heat transfer coefficient is a specific parameter relating to a component. It is determined largely by the thermal conductivity and thickness of the material in use, but also by the heat radiation and convection on the surfaces.

Note: Measurement of the thermal transfer coefficient requires stationary temperatures to prevent any falsification of the measurement findings by the heat storage capacity of the material.

- The higher the heat transfer coefficient, the worse the heat insulation properties of the material.

λ -

Thermal conductivity of a material

U_f value

the U_f value is the heat transfer coefficient of the frame. The f stands for frame. To calculate the U_f value, the window pane is replaced with a panel exhibiting:

$\lambda=0.035$ W/mK replaced.

U_g value

the U_g value is the heat transfer coefficient of the glazing.

U_p value

the U_p value is the heat transfer coefficient of the panel.

U_w value

the U_w value is the heat transfer coefficient of the window, comprising the U_f value of the frame and the U_g value of the glazing.

U_{cw} value

the U_{cw} value is the heat transfer coefficient of a curtain wall.

ψ_{f,g} value

Length-based heat transfer coefficient of the edge bonding (combination of frame and glazing).

Rs -

The heat transfer resistance Rs (previously: 1/α) describes the resistance with which the border layer opposes the medium (usually air) surrounding the component to prevent the flow of heat.

Basis of the calculation

9.4
3

Definitions:

R_{si}

Heat transfer resistance inside

R_{se}

Heat transfer resistance outside

T_{min}

Minimum inside surface temperature to determine the absence of condensation on window connections. The T_{min} of a component must be greater than the component's dew point.

f_{Rsi}

Used to determine the freedom of fungal growth on window connections.

The temperature factor f_{Rsi} is the difference between the temperature of the inside surface θ_{si} of a component and the outside air temperature θ_e , relative to the temperature difference between the inside θ_i and outside air θ_e .

A variety of requirements must be adhered to in order to introduce design measures to reduce the risk of fungal growth.

For instance, for all constructive, shape-related and material-related thermal bridges that deviate from DIN 4108-2, the temperature factor f_{Rsi} at the least favourable point must satisfy the minimum requirement:

$$f_{Rsi} \geq 0.70.$$

Basis of the calculation

9.4
3

Calculated according to DIN EN ISO 12631 - 01.2013

- Simplified assessment procedure
- Assessment of the individual components

Symbol	Size	Unit
A	Surface	m ²
T	Thermodynamic temperature	K
U	Heat transfer coefficient	W/(m ² ·K)
l	Length	m
d	Depth	m
Φ	Heat flow	W
ψ	Length-based heat transfer coefficient	W/(m·K)
Δ	Difference	
Σ	Sum	
ε	Emission level	
λ	Thermal conductivity	W/(m·K)
Indices		
g	Glazing	
p	Panel	
f	Frame	
m	Mullion	
t	Transom	
w	Window	
cw	Curtain wall	
Caption		
U _g , U _p	Heat transfer coefficient of filling	W/(m ² ·K)
U _f , U _t , U _m	Heat transfer coefficient of frame, mullion, transom	W/(m ² ·K)
A _g , A _p	Surface proportion of filling	m ²
A _f , A _t , A _m	Surface proportions of frame, mullion, transom	
ψ _{f,g} , ψ _{m,g} , ψ _{t,g} , ψ _p	Length-based heat transfer coefficient based on the combined thermal effects between the glazing, panels and frames - mullion/transom	W/(m·K)
ψ _{m,f} , ψ _{t,f}	Length-based heat transfer coefficient based on the combined thermal effects between the frames - mullion/transom	W/(m·K)

Basis of the calculation

9.4
3

Assessment of the individual components

The method to assess the individual components involves dividing a representative element into surfaces with different thermal properties, e.g. glazing, opaque panels and frames. (...) This method can be applied to curtain facades, e.g. element facades, mullion-transom facades and dry glazing. The method with assessment of the individual components is not suitable for SG glazing with silicone joints, rear-ventilated facades and SG glazing.

Formula

$$U_{cw} = \frac{\sum A_g U_g + \sum A_p U_p + \sum A_m U_m + \sum A_t U_t + \sum l_{fg} \psi_{fg} + \sum l_{mg} \psi_{mg} + \sum l_{tg} \psi_{tg} + \sum l_p \psi_p + \sum l_{mf} \psi_{mf} + \sum l_{tf} \psi_{tf}}{A_{cw}}$$

Calculation of the facade surface:

$$A_{cw} = A_g + A_p + A_f + A_m + A_t$$

Basis of the calculation

9.4
3

Glazed surfaces

The glazed surface A_g , i.e. the surface of the opaque panel A_p on a component, is the smaller of the surfaces visible on both sides. The areas in which the sealant overlaps the glazed surfaces is not considered.

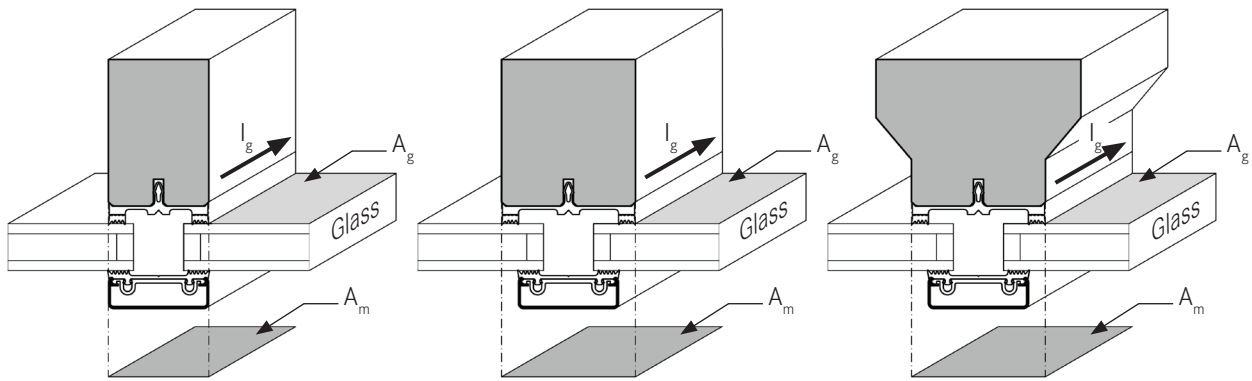

Surface proportion of the frame, mullion and transom

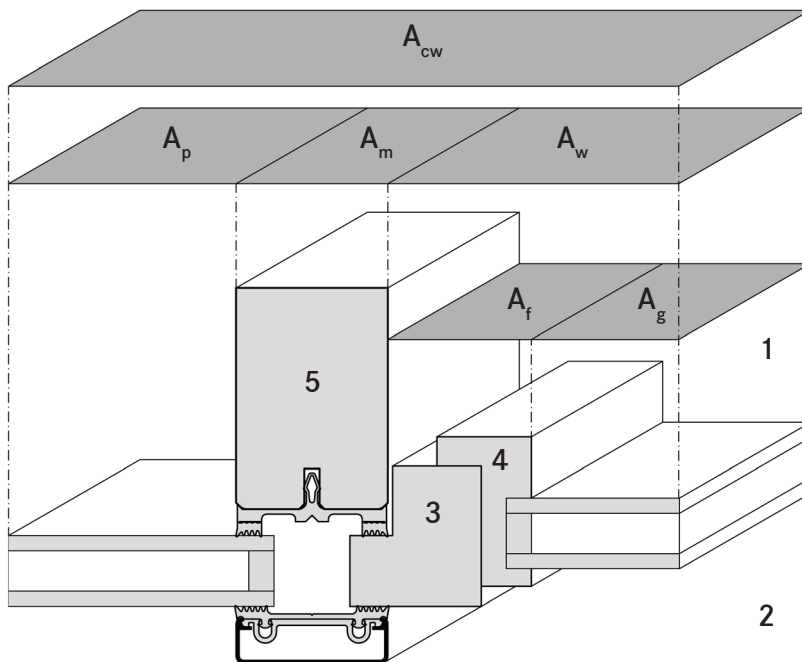

Caption

- | | |
|----------|--------------------------------|
| 1 | Room-side |
| 2 | Outer side |
| 3 | Fixed frame |
| 4 | Movable frame |
| 5 | Mullion/transom |
| A_{cw} | Surface of the curtain wall |
| A_p | Surface of the panel |
| A_m | Surface of the mullion |
| A_f | Surface of the window frame |
| A_g | Surface of the window glazing |
| A_w | Surface of the complete window |

Basis of the calculation

9.4
3

Planes in the geometric model (U)

A representative facade element is selected in order to calculate the heat transfer coefficient **U** for each area. This section must include all of the elements with varying thermal properties that are present in the facade. They include glazing, panels, parapets and their connections, as well as mullions, transoms and silicone joints.

The planes must have adiabatic borders. They may be:

- Symmetrical planes or
- planes in which the thermal flow passes at right angles to the level of the curtain facade, i.e. where there are no edge influences (e.g. at an interval of 190 mm to the edge of a double-glazed window).

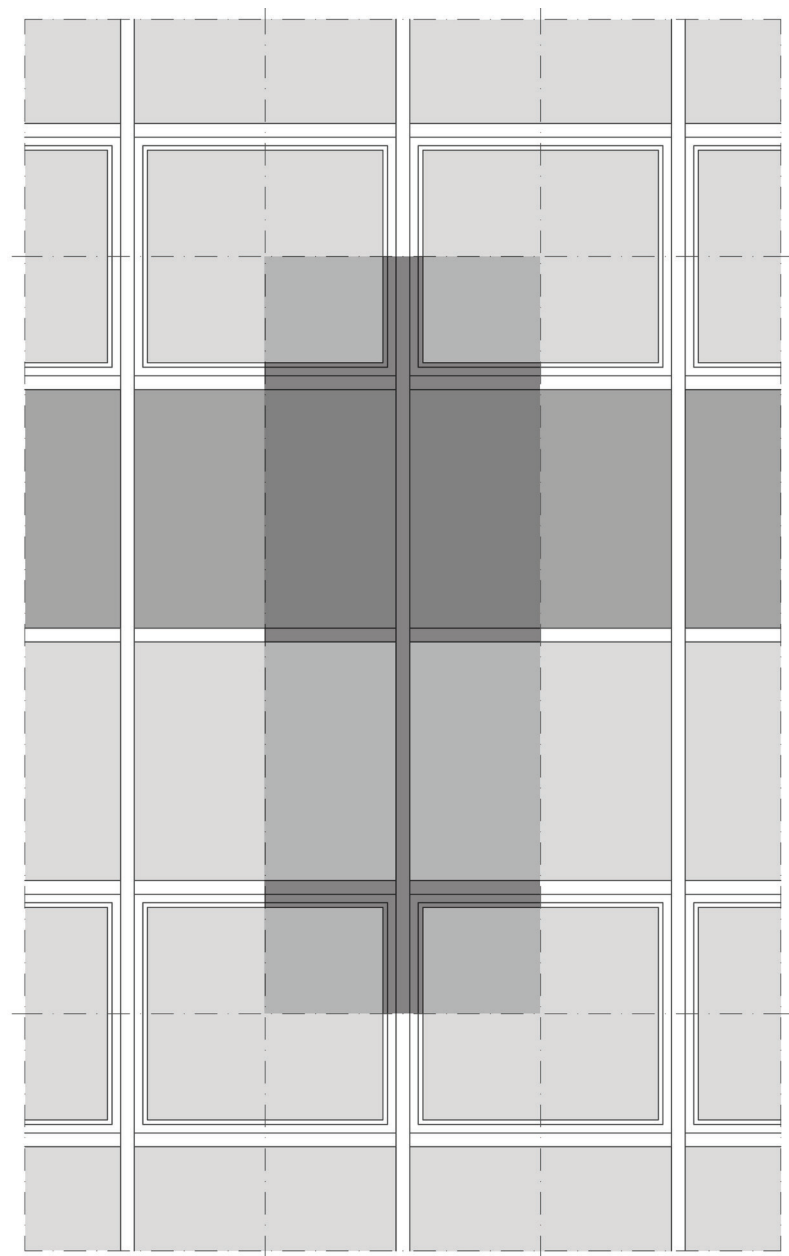

Basis of the calculation

9.4
3

Limits of a representative reference part in a facade (U_{cw})

The representative reference element is divided into surfaces with different thermal properties in order to calculate the U_{cw} .

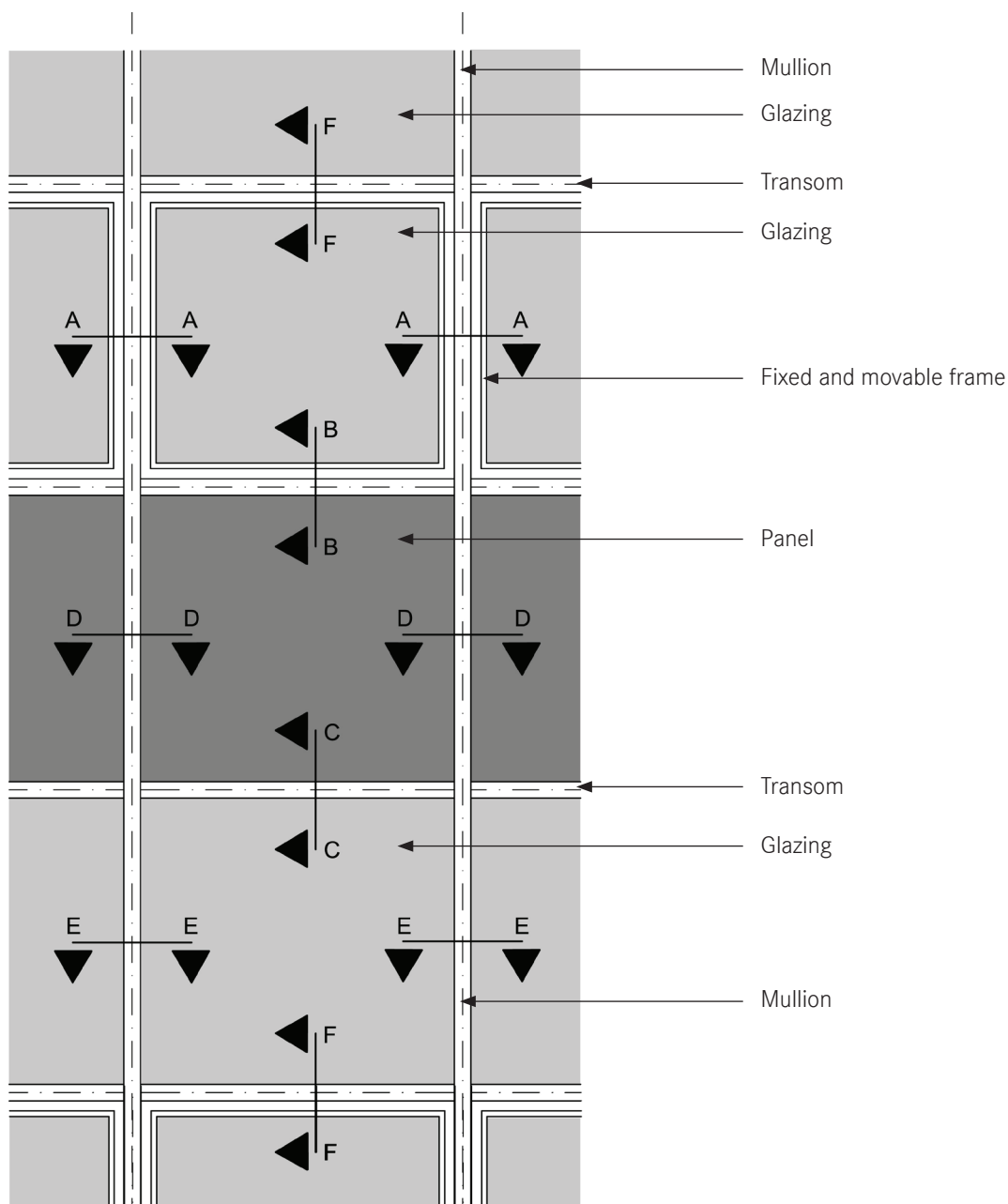

TI-H_9.4_001.dwg

Basis of the calculation

$\frac{9.4}{3}$

Cuts

F - F

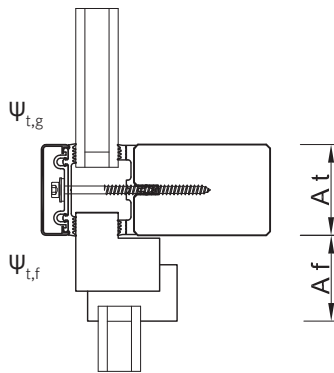

B - B

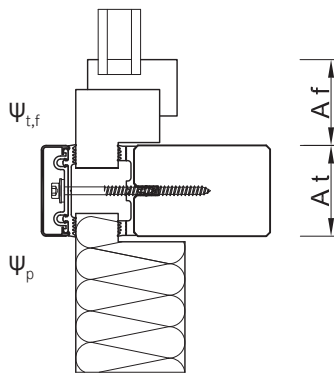

C - C

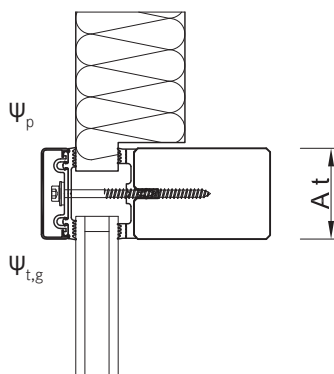

A - A

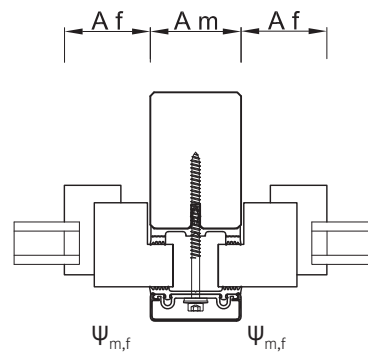

D - D

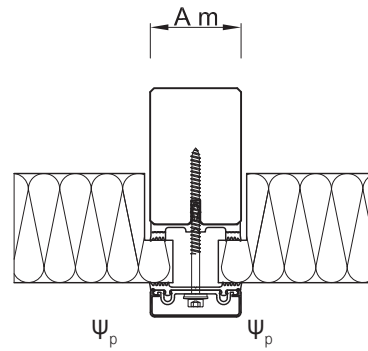

E - E

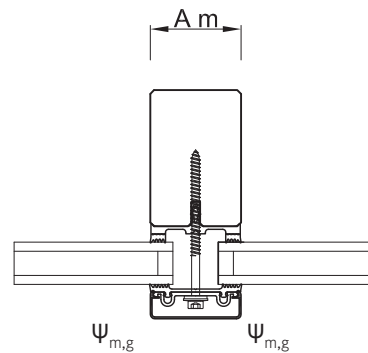

Basis of the calculation

$\frac{9.4}{3}$

Calculation example

Facade section

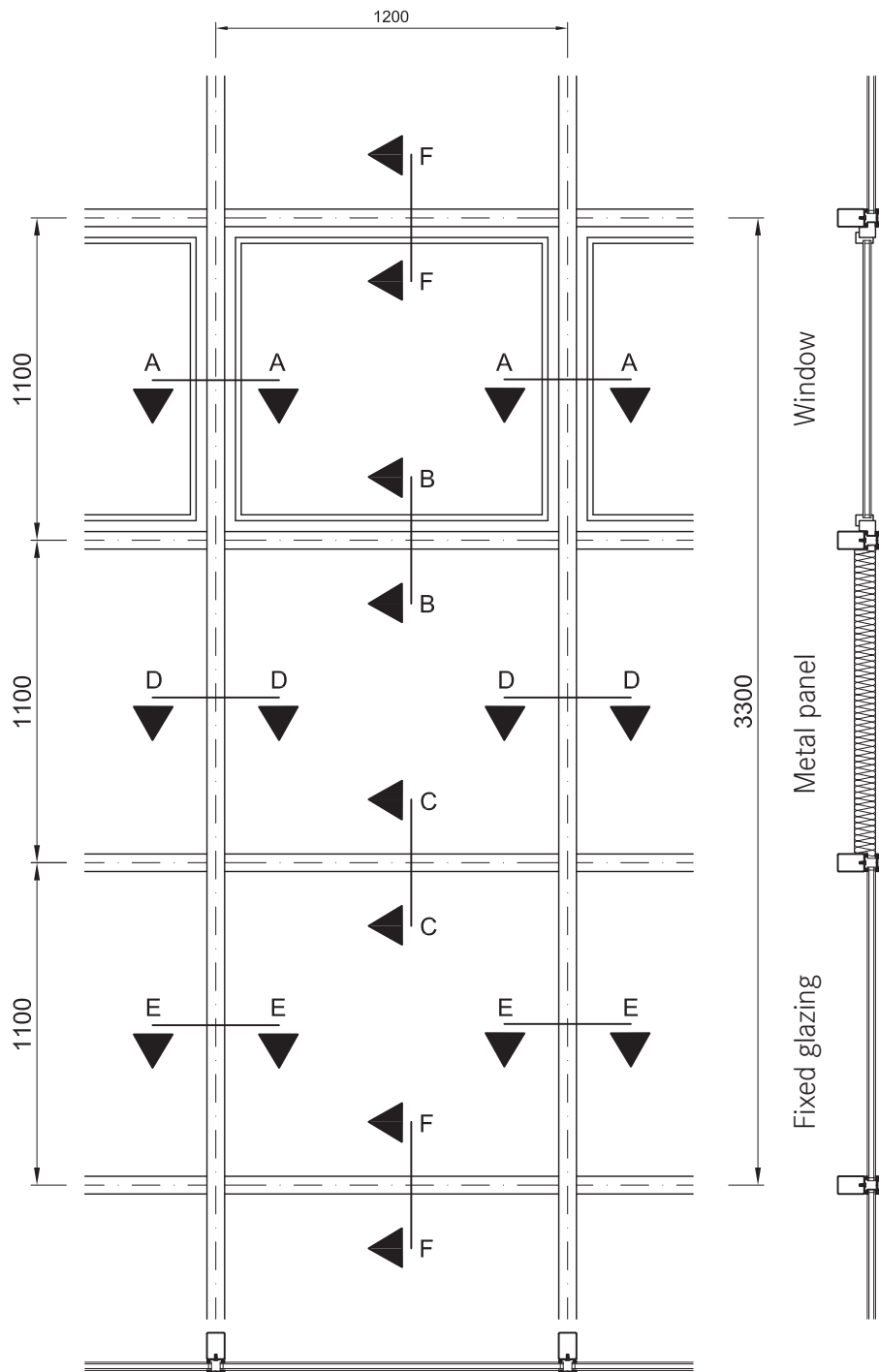

Basis of the calculation

9.4
3

Calculation example

Calculation of surfaces and lengths

Mullion, transom and frame:

Width of mullion (m)	50 mm
Width of transom (t)	50 mm
Width of window frame (f)	80 mm
$A_m = 2 \cdot 3.30 \cdot 0.025$	$= 0.1650 \text{ m}^2$
$A_t = 3 \cdot (1.2 - 2 \cdot 0.025) \cdot 0.025$	$= 0.1725 \text{ m}^2$
$A_f = 2 \cdot 0.08 \cdot (1.20 + 1.10 - 4 \cdot 0.025 - 2 \cdot 0.08)$	$= 0.1650 \text{ m}^2$

Panel surface element

$b = 1.20 - 2 \cdot 0.025$	$= 1.15 \text{ m}$
$h = 1.10 - 2 \cdot 0.025$	$= 1.05 \text{ m}$
$A_p = 1.15 \cdot 1.05$	$= 1.2075 \text{ m}^2$
$l_p = 2 \cdot 1.15 + 2 \cdot 1.05$	$= 4.40 \text{ m}$

Glass surface element - movable part:

$b = 1.20 - 2 \cdot (0.025 + 0.08)$	$= 0.99 \text{ m}$
$h = 1.10 - 2 \cdot (0.025 + 0.08)$	$= 0.89 \text{ m}$
$A_{g1} = 0.89 \cdot 0.99$	$= 0.8811 \text{ m}^2$
$l_{g1} = 2 \cdot (0.99 + 0.89)$	$= 3.76 \text{ m}$

Glass surface element - fixed part:

$b = 1.20 - 2 \cdot 0.025$	$= 1.15 \text{ m}$
$h = 1.10 - 2 \cdot 0.025$	$= 1.05 \text{ m}$
$A_p = 1.15 \cdot 1.05$	$= 1.2075 \text{ m}^2$
$l_p = 2 \cdot 1.15 + 2 \cdot 1.05$	$= 4.40 \text{ m}$

Calculation of the U_i values: example

U values	Determined based on the	Calculation value U_i [W/(m ² ·K)]
U_g (glazing)	DIN EN 673 ¹ / 674 ² / 675 ²	1.20
U_p (Panel)	DIN EN ISO 6946 ¹	0.46
U_m (mullion)	DIN EN 12412-2 ² / DIN EN ISO 10077-2 ¹	2.20
U_t (transom)	DIN EN 12412-2 ² / DIN EN ISO 10077-2 ¹	1.90
U_f (frame)	DIN EN 12412-2 ² / DIN EN ISO 10077-2 ¹	2.40
$\Psi_{f,g}$		0.11
Ψ_p	DIN EN ISO 10077-2 ¹ /	0.18
$\Psi_{m,g} / \Psi_{t,g}$	DIN EN ISO 12631 - 01.2013 Annex B	0.17
$\Psi_{m,f} / \Psi_{t,f}$		0.07 - Type D2

¹ Calculation, ² Measurement

Basis of the calculation

9.4
3

Calculation example

Results

	A [m ²]	U _i [W/(m ² ·K)]	l [m]	ψ [W/(m·K)]	A · U [W/K]	ψ · l [W/K]
Mullion	A _m = 0.1650	U _m = 2.20			0.363	
Transom	A _t = 0.1725	U _t = 1.90			0.328	
Frame	A _f = 0.3264	U _f = 2.40			0.783	
Mullion-frame			l _{m,f} = 2.20	ψ _{m,f} = 0.07		0.154
Transom-frame			l _{t,f} = 2.20	ψ _{t,f} = 0.07		0.154
Glazing:						
- movable	A _{g,1} = 0.8811	U _{g,1} = 1.20	l _{f,g} = 3.76	ψ _{g,1} = 0.11	1.057	0.414
- fixed	A _{g,2} = 1.2075	U _{g,2} = 1.20	l _{m,g} = 4.40	ψ _{g,2} = 0.17	1.449	0.784
Panel	A _p = 1.2705	U _p = 0.46	l _p = 4.40	ψ _p = 0.18	0.556	0.792
Sum	A_{cw} = 3.96				4.536	2.262

$$U_{cw} = \frac{\Sigma A \cdot U + \Sigma \psi \cdot l}{A_{cw}} = \frac{4.536 + 2.262}{3.96} = 1.72 \text{ W/(m}^2\cdot\text{K)}$$

Basis of the calculation

9.4
3

Calculation of the ψ - values according to DIN EN ISO 12631 - 01.2013 - Annex B - Glazing

Type of mullion/transom	Type of glazing	
	ψ [W/(m·K)]	ψ [W/(m·K)]
	Double or triple glazing (6mm glass), <ul style="list-style-type: none"> uncoated glass with air or gas gap 	Double or triple glazing (6mm glass), <ul style="list-style-type: none"> Glass with low emission level Single coating with double glazing Single coating with double glazing with air or gas gap
Table B.1	Aluminium and steel spacers in mullion or transom profiles $\psi_{m,g}$, $\psi_{t,g}$	
Timber-aluminium	0.08	0.08
Metal frame with thermal separation	$d_i \leq 100$ mm: 0.13 $d_i \leq 200$ mm: 0.15	$d_i \leq 100$ mm: 0.17 $d_i \leq 200$ mm: 0.19
Table B.2	Spacer with improved thermal properties in the mullion or transom profiles $\psi_{m,g}$, $\psi_{t,g}$	
Timber-aluminium	0.06	0.08
Metal frame with thermal separation	$d_i \leq 100$ mm: 0.09 $d_i \leq 200$ mm: 0.10	$d_i \leq 100$ mm: 0.11 $d_i \leq 200$ mm: 0.12
Table B.3	Aluminium and steel spacers in window frames $\psi_{f,g}$ (also insert elements in facades)	
Table based on DIN EN 10077-1		
Timber-aluminium	0.06	0.08
Metal frame with thermal separation	0.08	0.11
Metal frame without thermal separation	0.02	0.05
Table B.4	Spacer with improved thermal properties in the window frame $\psi_{f,g}$ (also insert elements in facades)	
Table based on DIN EN 10077-1		
Timber-aluminium	0.05	0.06
Metal frame with thermal separation	0.06	0.08
Metal frame without thermal separation	0.01	0.04

d_i room-side depth of the mullion/transom

Basis of the calculation

9.4
3

Data sheet “Warm edge” (spacer with improved thermal properties) Psi values for windows*

Product name	Metal with thermal separation		Plastic		Timber		Timber/metal	
	V ¹ Ug = 1.1	V ² Ug = 0.7	V ¹ Ug = 1.1	V ² Ug = 0.7	V ¹ Ug = 1.1	V ² Ug = 0.7	V ¹ Ug = 1.1	V ² Ug = 0.7
Chromatech Plus (stainless steel)	0.067	0.063	0.051	0.048	0.052	0.052	0.058	0.057
Chromatech (stainless steel)	0.069	0.065	0.051	0.048	0.053	0.053	0.059	0.059
GTS (stainless steel)	0.069	0.061	0.049	0.046	0.051	0.051	0.056	0.056
Chromatech Ultra (stainless steel/polycarbonate)	0.051	0.045	0.041	0.038	0.041	0.040	0.045	0.043
WEB premium (stainless steel)	0.068	0.063	0.051	0.048	0.053	0.052	0.058	0.058
WEB classic (stainless steel)	0.071	0.067	0.052	0.049	0.054	0.055	0.060	0.061
TPS (polyisobutylene)	0.047	0.042	0.039	0.037	0.038	0.037	0.042	0.040
Thermix TX.N (stainless steel/plastic)	0.051	0.045	0.041	0.038	0.041	0.039	0.044	0.042
TGI Spacer (stainless steel/plastic)	0.056	0.051	0.044	0.041	0.044	0.043	0.049	0.047
Swisspacer V (stainless steel/plastic)	0.039	0.034	0.034	0.032	0.032	0.031	0.035	0.033
Swisspacer (stainless steel/plastic)	0.060	0.056	0.045	0.042	0.047	0.046	0.052	0.051
Super Spacer TriSeal (mylar foil/silicone foam)	0.041	0.036	0.035	0.033	0.034	0.032	0.037	0.035
Nirotec 015 (stainless steel)	0.066	0.061	0.050	0.047	0.051	0.051	0.057	0.056
Nirotec 017 (stainless steel)	0.068	0.063	0.051	0.048	0.053	0.053	0.058	0.058

V¹ - Double pane insulating glass Ug 1.1 W/(m²K)

V² - Triple pane insulating glass Ug 0.7 W/(m²K)

* Values calculated by University of Applied Sciences Rosenheim and **ift Rosenheim**

Basis of the calculation

9.4
3

Calculation of the ψ - values according to DIN EN ISO 12631 - 1.2013 - Annex B - Panels

Table B.5

Values of the length-based heat transfer coefficient for
the panel spacers ψ_p

Type of filling Inside, i.e. outside panelling	Thermal conductivity of the spacer λ [W/(m·K)]	length-based heat transfer coefficient* ψ [W/(m·K)]
Panel type 1 with panelling:	-	0.13
Aluminium/aluminium		
Aluminium/glass		
Steel/glass		
Panel type 2 with panelling:		
Aluminium/aluminium	0.2	0.20
	0.4	0.29
Aluminium/glass	0.2	0.18
	0.4	0.20
Steel/glass	0.2	0.14
	0.4	0.18

*It is permitted to use this value if no data is available from measurements or detailed calculations.

Panel type 1

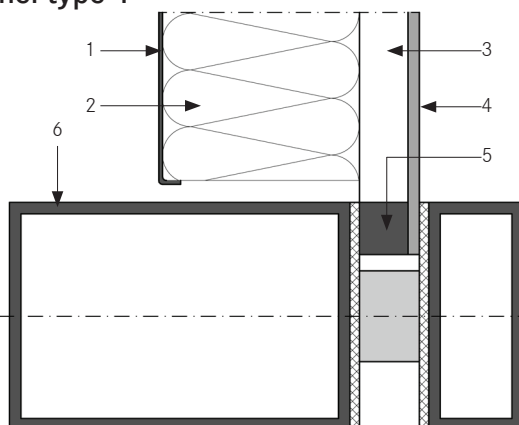

Caption

- 1 Aluminium 2.5 mm/Steel 2.0 mm
- 2 Insulation $\lambda= 0.025$ to 0.04 W/(m·K)
- 3 Air-filled gap 0 to 20 mm
- 4 Aluminium 2.5 mm/Glass 6 mm
- 5 Spacer $\lambda= 0.2$ to 0.4 W/(m·K)
- 6 Aluminium

Panel type 2

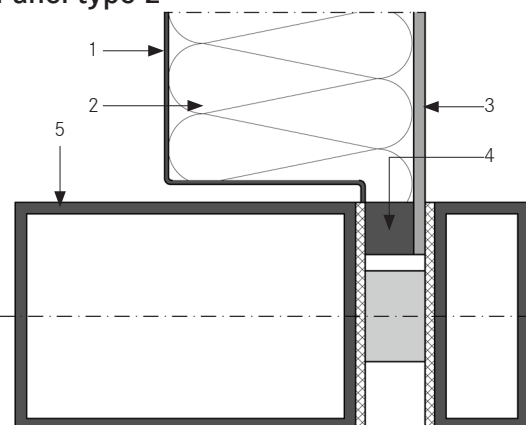

Caption

- 1 Aluminium 2.5 mm/Steel 2.0 mm
- 2 Insulation $\lambda= 0.025$ to 0.04 W/(m·K)
- 3 Aluminium 2.5 mm/Glass 6 mm
- 4 Spacer $\lambda= 0.2$ to 0.4 W/(m·K)
- 5 Aluminium

TI-H_9.4_001.dwg

Basis of the calculation

9.4
3

Calculation of the ψ - values according to
DIN EN ISO 12631 - 1.2013 - Annex B - Insert elements

Table B.6 Values of the length-based heat transfer coefficient for the connecting area of mullions/transoms and alu/steel frames $\psi_{m/t,f}$

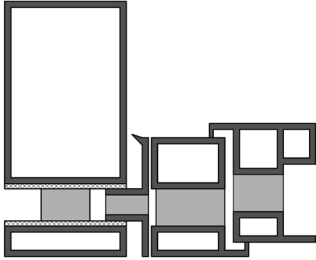
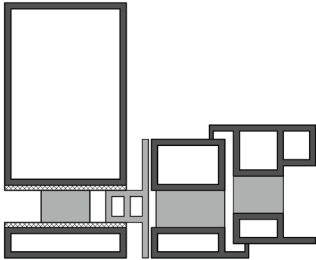
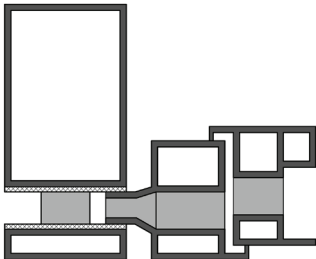
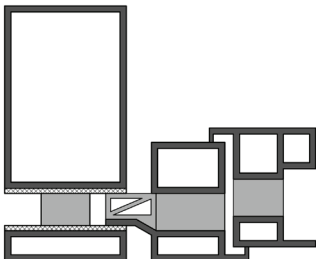
Types of connection areas	Diagram	Description	Length-based heat transfer coefficient* $\psi_{m,f}$ or $\psi_{t,f}$ [W/(m·K)]
A		Installation of the frame in the mullion with an additional aluminium profile with thermal separation zone	0.11
B		Installation of the frame in the mullion with an additional profile with low thermal conductivity (e.g. polyamide 6.6 with a glass fibre content of 25%)	0.05
C1		Installation of the frame in the mullion with extension of the thermal separation of the frame	0.07
C2		Installation of the frame in the mullion with extension of the thermal separation of the frame (e.g. polyamide 6.6 with a glass fibre content of 25%)	0.07

Values for ψ not included in the table can be determined by numerical calculation according to EN ISO 10077-2.

TI-H_9.4_001.dwg

Basis of the calculation

9.4
3

Calculation of the ψ - values according to DIN EN ISO 12631 - 1.2013 - Annex B - Insert elements

Table B.6 Values of the length-based heat transfer coefficient for the connecting area of mullions/transoms and alu/steel frames $\psi_{m/t,f}$

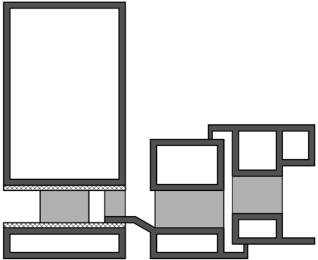
Types of connection areas	Diagram	Description	Length-based heat transfer coefficient* $\psi_{m,f}$ or $\psi_{t,f}$ [W/(m·K)]
D		Installation of the frame in the mullion with extension of the external aluminium profile. Filling material for the attachment with low thermal conductivity $\lambda = 0.3 \text{ W/(m·K)}$	0.07

*It is permitted to use this value if no data is available from measurements or detailed calculations. These values only apply if the mullion/transom and the frame possess thermal zones and no other part of the frame without a thermal separation zone interrupts a thermal separation zone.

Table B.7 Values of the length-based heat transfer coefficient for the connecting area of mullions/transoms and timber/aluminium frames $\psi_{m/t,f}$

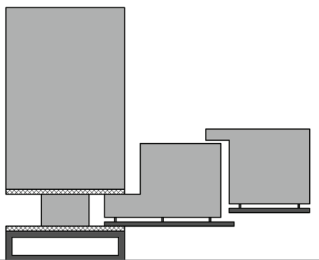
Types of connection areas	Diagram	Description	Length-based heat transfer coefficient* $\psi_{m,f}$ or $\psi_{t,f}$ [W/(m·K)]
A		$U_m > 2.0 \text{ W/(m}^2\cdot\text{K)}$	0.02
B		$U_m \leq 2.0 \text{ W/(m}^2\cdot\text{K)}$	0.04

Basis of the calculation

9.4
3

Heat transfer coefficient of glass (U_g) according to DIN EN 10077-1 - Annex C

Table C.2 Heat transfer coefficient of double and triple-pane insulating glazing with various gas fillings for glazing mounted vertically U_g

Type	Glass	Standard emission level	Dimensions mm	Heat transition coefficient for various types of gas gaps* U_g [W/(m ² ·K)]				
				Air	Argon	Krypton	SF ₆ **	Xenon
Double pane insulating glazing	uncoated glass (Normal glass)	0.89	4-6-4	3.3	3.0	2.8	3.0	2.6
			4-8-4	3.1	2.9	2.7	3.1	2.6
			4-12-4	2.8	2.7	2.6	3.1	2.6
			4-16-4	2.7	2.6	2.6	3.1	2.6
			4-20-4	2.7	2.6	2.6	3.1	2.6
	One pane of coated glass	≤ 0.20	4-6-4	2.7	2.3	1.9	2.3	1.6
			4-8-4	2.4	2.1	1.7	2.4	1.6
			4-12-4	2.0	1.8	1.6	2.4	1.6
			4-16-4	1.8	1.6	1.6	2.5	1.6
			4-20-4	1.8	1.7	1.6	2.5	1.7
	One pane of coated glass	≤ 0.15	4-6-4	2.6	2.3	1.8	2.2	1.5
			4-8-4	2.3	2.0	1.6	2.3	1.4
			4-12-4	1.9	1.6	1.5	2.3	1.5
			4-16-4	1.7	1.5	1.5	2.4	1.5
			4-20-4	1.7	1.5	1.5	2.4	1.5
	One pane of coated glass	≤ 0.10	4-6-4	2.6	2.2	1.7	2.1	1.4
			4-8-4	2.2	1.9	1.4	2.2	1.3
			4-12-4	1.8	1.5	1.3	2.3	1.3
			4-16-4	1.6	1.4	1.3	2.3	1.4
			4-20-4	1.6	1.4	1.4	2.3	1.4
One pane of coated glass	≤ 0.05	4-6-4	2.5	2.1	1.5	2.0	1.2	
		4-8-4	2.1	1.7	1.3	2.1	1.1	
		4-12-4	1.7	1.3	1.1	2.1	1.2	
		4-16-4	1.4	1.2	1.2	2.2	1.2	
		4-20-4	1.5	1.2	1.2	2.2	1.2	
Triple pane insulating glazing	uncoated glass (Normal glass)	0.89	4-6-4-6-4	2.3	2.1	1.8	1.9	1.7
			4-8-4-8-4	2.1	1.9	1.7	1.9	1.6
			4-12-4-12-4	1.9	1.8	1.6	2.0	1.6
	2 panes coated	≤ 0.20	4-6-4-6-4	1.8	1.5	1.1	1.3	0.9
			4-8-4-8-4	1.5	1.3	1.0	1.3	0.8
			4-12-4-12-4	1.2	1.0	0.8	1.3	0.8
	2 panes coated	≤ 0.15	4-6-4-6-4	1.7	1.4	1.1	1.2	0.9
			4-8-4-8-4	1.5	1.2	0.9	1.2	0.8
			4-12-4-12-4	1.2	1.0	0.7	1.3	0.7
	2 panes coated	≤ 0.10	4-6-4-6-4	1.7	1.3	1.0	1.1	0.8
			4-8-4-8-4	1.4	1.1	0.8	1.1	0.7
			4-12-4-12-4	1.1	0.9	0.6	1.2	0.6
	2 panes coated	≤ 0.05	4-6-4-6-4	1.6	1.2	0.9	1.1	0.7
			4-8-4-8-4	1.3	1.0	0.7	1.1	0.5
			4-12-4-12-4	1.0	0.8	0.5	1.1	0.5

* Gas concentration 90%

** The use of SF₆ is prohibited in some countries.

Basis of the calculation

9.4
3

Summary

The following information is needed to calculate the

U_{cw} :

U values	Determined based on the	source
U_g (glazing)	DIN EN 673 ¹ / 674 ² / 675 ²	Manufacturer's specifications
U_p (panel)	DIN EN ISO 6946 ¹	Manufacturer's specifications
U_m (mullion)	DIN EN 12412-2 ² / DIN EN ISO 10077-2 ¹	Norden Facade documents / or individual calculation*
U_t (transom)	DIN EN 12412-2 ² / DIN EN ISO 10077-2 ¹	Norden Facade documents / or individual calculation*
U_f (frame/window)	DIN EN 12412-2 ² / DIN EN ISO 10077-2 ¹	Manufacturer's specifications
$\Psi_{f,g}$		Calculation according to DIN EN 10077-2 if the spacer for the glazing is known, otherwise according to DIN EN ISO 12631 - 01.2013 Annex B or itf table "Warm Edge"
Ψ_p	DIN EN ISO 10077-2 ¹ /	
$\Psi_{m,g} / \Psi_{t,g}$	DIN EN ISO 12631 - 01.2013 Annex B	Calculation according to DIN EN 10077-2 if the structure is known, otherwise according to DIN EN ISO 12631 - 1.2013 Annex B
$\Psi_{m,f} / \Psi_{t,f}$		
Facade geometry or a representative facade section with all dimensions and fillings as in the glass/panel/installation element		Planner's specifications

¹ Calculation, ² Measurement

* Norden Facade Customer Service

U_f values

9.4
4

Determination of the U_f values according to
DIN EN 10077-2

Norden Facade H

50120
Glass inset 15

Values without effect of screws*

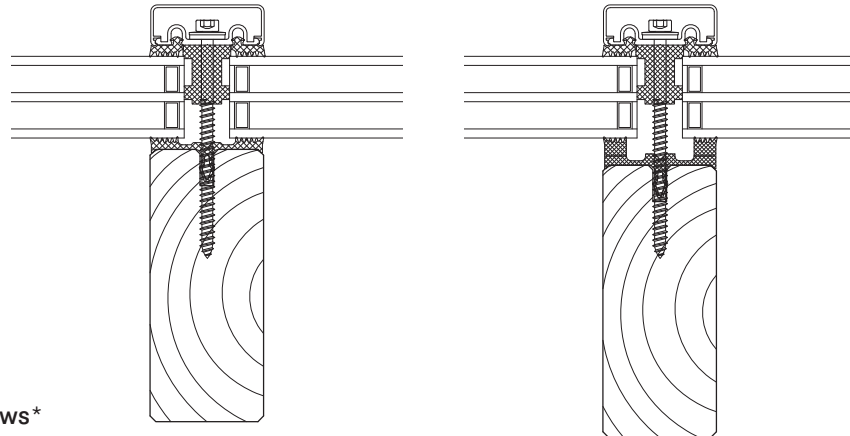

System	5 mm seal			12 mm seal				
	U_f (W/m ² K) with isolator	U_f (W/m ² K) without isolator		U_f (W/m ² K) with isolator	U_f (W/m ² K) without isolator			
Outer seal	GD 1934		GD 5024	GD 1934	GD 1934		GD 5024	GD 1934
H-50120-24-15	(Z0606)	0.925	1.468	1,241	(Z0606)	0.933	1.574	1,343
H-50120-26-15	(Z0606)	0.900	1.454	1,224	(Z0606)	0.911	1.555	1,322
H-50120-28-15	(Z0606)	0.868	1.431	1,197	(Z0606)	0.882	1.528	1,293
H-50120-30-15	(Z0606)	0.843	1.412	1,174	(Z0606)	0.862	1.505	1,268
H-50120-32-15	(Z0606)	0.828	1.402	1,160	(Z0606)	0.850	1.491	1,251
H-50120-34-15	(Z0606)	0.807	1.385	1,142	(Z0605)	0.732	1.471	1,231
H-50120-36-15	(Z0606)	0.797	1.374	1,128	(Z0605)	0.711	1.456	1,214
H-50120-38-15	(Z0605)	0.688	1.361	1,113	(Z0605)	0.689	1.440	1,198
H-50120-40-15	(Z0605)	0.663	1.345	1,095	(Z0605)	0.666	1.421	1,177
H-50120-44-15	(Z0605)	0.629	1.324	1,070	(Z0605)	0.635	1.393	1,148
H-50120-48-15	(Z0605)	0.605	1.306	1,050	(Z0605)	0.615	1.371	1,124
H-50120-52-15	(Z0605)	0.587	1.292	1,033	(Z0605)	0.601	1.351	1,104
H-50120-56-15	(Z0605)	0.574	1.277	1,015	(Z0605)	0.588	1.332	1,083

Passive house-suitable

Passive house-suitable

* Effects of screws per piece 0.00322 W/K, for System 50 mm and with screw spacing of 250 mm = + 0.26 W/(m²·K)
Screw effects according to ebök (12.2008)

TI-H_9.4_002.dwg

U_f values

9.4
4

Determination of the U_f values according to
DIN EN 10077-2

Norden Facade H

60120
Glass inset 15

Values without effect of screws*

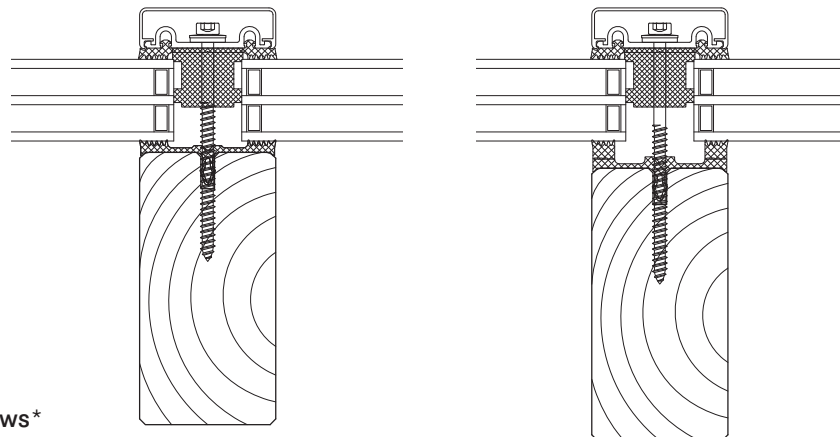

System	5 mm seal				12 mm seal			
	U_f (W/m ² K) with isolator		U_f (W/m ² K) without isolator		U_f (W/m ² K) with isolator		U_f (W/m ² K) without isolator	
Outer seal	GD 1934		GD 6024	GD 1934	GD 1934		GD 6024	GD 1934
H-60120-24-15	(Z0608)	0.903	1.561	1,252	(Z0608)	0.916	1.697	1,381
H-60120-26-15	(Z0608)	0.881	1.551	1,239	(Z0608)	0.897	1.684	1,365
H-60120-28-15	(Z0608)	0.855	1.535	1,218	(Z0608)	0.874	1.664	1,342
H-60120-30-15	(Z0608)	0.833	1.520	1,200	(Z0608)	0.856	1.645	1,321
H-60120-32-15	(Z0608)	0.820	1.512	1,189	(Z0608)	0.848	1.635	1,309
H-60120-34-15	(Z0608)	0.805	1.501	1,175	(Z0607)	0.713	1.620	1,292
H-60120-36-15	(Z0608)	0.797	1.492	1,164	(Z0607)	0.693	1.608	1,279
H-60120-38-15	(Z0607)	0.669	1.484	1,153	(Z0607)	0.675	1.596	1,264
H-60120-40-15	(Z0607)	0.650	1.471	1,138	(Z0607)	0.655	1.581	1,248
H-60120-44-15	(Z0607)	0.621	1.455	1,118	(Z0607)	0.630	1.559	1,225
H-60120-48-15	(Z0607)	0.600	1.441	1,101	(Z0607)	0.613	1.541	1,205
H-60120-52-15	(Z0607)	0.585	1.431	1,088	(Z0607)	0.602	1.526	1,188
H-60120-56-15	(Z0607)	0.577	1.420	1,075	(Z0607)	0.593	1.512	1,173

Passive house-suitable

Passive house-suitable

* Effects of screws per piece 0.00322 W/K, for System 60 mm and with screw spacing of 250 mm = + 0.21 W/(m²·K)
Screw effects according to ebök (12.2008)

TI-H_9.4_002.dwg

U_f values

9.4
4

Determination of the U_f values according to
DIN EN 10077-2

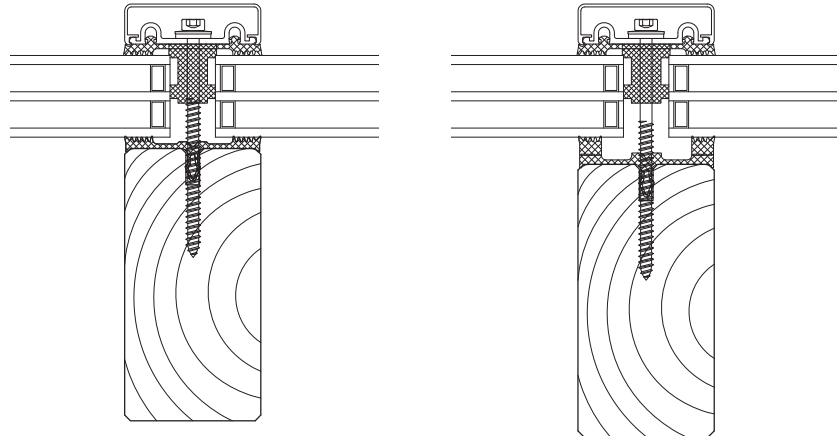

Norden Facade H

60120
Glass inset 20

Values without effect of
screws*

System	5 mm seal			12 mm seal				
	U_f (W/m ² K) with isolator	U_f (W/m ² K) without isolator		U_f (W/m ² K) with isolator	U_f (W/m ² K) without isolator			
Outer seal	GD 1934		GD 6024	GD 1934	GD 1934		GD 6024	GD 1934
H-60120-24-20	(Z0606)	0.902	1.305	1,164	(Z0606)	0.909	1.413	1,252
H-60120-26-20	(Z0606)	0.875	1.285	1,138	(Z0606)	0.885	1.390	1,228
H-60120-28-20	(Z0606)	0.843	1.259	1,110	(Z0606)	0.855	1.361	1,198
H-60120-30-20	(Z0606)	0.816	1.236	1,084	(Z0606)	0.832	1.334	1,170
H-60120-32-20	(Z0606)	0.797	1.221	1,067	(Z0606)	0.817	1.316	1,151
H-60120-34-20	(Z0606)	0.776	1.201	1,047	(Z0605)	0.717	1.294	1,128
H-60120-36-20	(Z0606)	0.759	1.186	1,029	(Z0605)	0.696	1.276	1,109
H-60120-38-20	(Z0605)	0.695	1.161	1,013	(Z0605)	0.675	1.258	1,091
H-60120-40-20	(Z0605)	0.650	1.142	0,993	(Z0605)	0.652	1.237	1,069
H-60120-44-20	(Z0605)	0.615	1.126	0,965	(Z0605)	0.621	1.206	1,037
H-60120-48-20	(Z0605)	0.588	1.103	0,940	(Z0605)	0.597	1.179	1,010
H-60120-52-20	(Z0605)	0.566	1.085	0,919	(Z0605)	0.580	1.156	0,986
H-60120-56-20	(Z0605)	0.549	1.067	0,899	(Z0605)	0.564	1.135	0,964

Passive house-suitable

Passive house-suitable

* Effects of screws per piece 0.00322 W/K, for System 60 mm and with screw spacing of 250 mm = + 0.21 W/(m²·K)
Screw effects according to ebök (12.2008)

TI-H_9.4_002.dwg

U_f values

9.4
4

Determination of the U_f values according to
DIN EN 10077-2

Norden Facade H

80120
Glass inset 20

Values without effect of
screws*

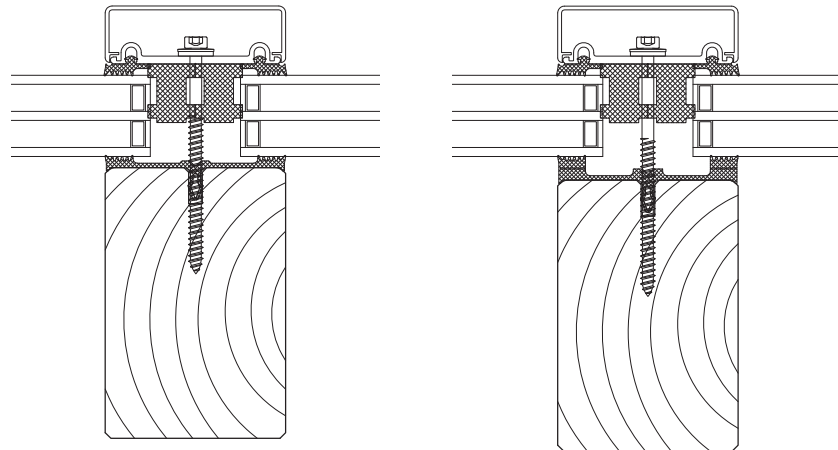

System	5 mm seal			12 mm seal		
	U_f (W/m ² K) with isolator	U_f (W/m ² K) without isolator		U_f (W/m ² K) with isolator	U_f (W/m ² K) without isolator	
Outer seal	GD 1934	GD 8024	GD 1934	GD 1934	GD 8024	GD 1934
H-80120-24-20	(2xZ0606) 0,880	1,439	1,196	(2xZ0606) 0,873	1,555	1,298
H-80120-26-20	(2xZ0606) 0,857	1,426	1,182	(2xZ0606) 0,855	1,541	1,282
H-80120-28-20	(2xZ0606) 0,831	1,409	1,163	(2xZ0606) 0,833	1,521	1,262
H-80120-30-20	(2xZ0606) 0,809	1,393	1,146	(2xZ0606) 0,816	1,504	1,244
H-80120-32-20	(2xZ0606) 0,795	1,383	1,136	(2xZ0606) 0,806	1,493	1,231
H-80120-34-20	(2xZ0606) 0,778	1,371	1,122	(2xZ0606) 0,793	1,478	1,216
H-80120-36-20	(2xZ0606) 0,767	1,361	1,111	(2xZ0606) 0,784	1,467	1,204
H-80120-38-20	(2xZ0606) 0,757	1,350	1,100	(2xZ0605) 0,648	1,455	1,191
H-80120-40-20	(2xZ0605) 0,637	1,338	1,086	(2xZ0605) 0,631	1,440	1,179
H-80120-44-20	(2xZ0605) 0,608	1,320	1,068	(2xZ0605) 0,607	1,419	1,155
H-80120-48-20	(2xZ0605) 0,587	1,305	1,051	(2xZ0605) 0,590	1,401	1,135
H-80120-52-20	(2xZ0605) 0,570	1,292	1,038	(2xZ0605) 0,578	1,385	1,120
H-80120-56-20	(2xZ0605) 0,560	1,280	1,025	(2xZ0605) 0,568	1,371	1,104

Passive house-suitable

Passive house-suitable

* Effects of screws per piece 0.00322 W/K, for System 80 mm and with screw spacing of 250 mm = + 0.16 W/(m²·K)
Screw effects according to ebök (12.2008)

TI-H_9.4_002.dwg

U_f values

9.4
4

Determination of the U_f values according to
DIN EN 10077-2

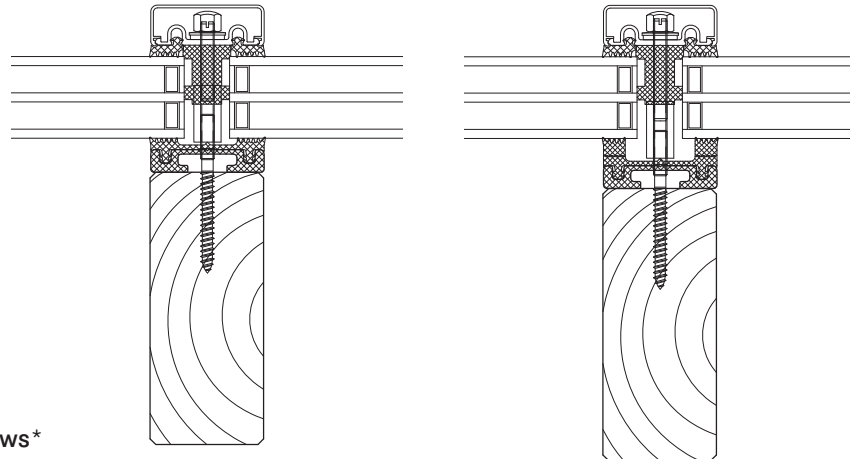

Norden Facade ZL-H

50120
Glass inset 15

Values without effect of screws*

System	5 mm seal			12 mm seal				
	U_f (W/m ² K) with isolator		U_f (W/m ² K) without isolator	U_f (W/m ² K) with isolator		U_f (W/m ² K) without isolator		
Outer seal	GD 1934		GD 5024	GD 1934	GD 1934			
ZL-H-50120-24-15	(Z0606)	0.926	1.444	1,244	(Z0606)	0.937	1.579	1,354
ZL-H-50120-26-15	(Z0606)	0.900	1.429	1,226	(Z0606)	0.914	1.561	1,333
ZL-H-50120-28-15	(Z0606)	0.868	1.406	1,199	(Z0606)	0.886	1.533	1,304
ZL-H-50120-30-15	(Z0606)	0.842	1.387	1,176	(Z0606)	0.865	1.509	1,278
ZL-H-50120-32-15	(Z0606)	0.826	1.376	1,162	(Z0606)	0.853	1.494	1,262
ZL-H-50120-34-15	(Z0606)	0.805	1.360	1,144	(Z0605)	0.733	1.474	1,240
ZL-H-50120-36-15	(Z0606)	0,794	1.349	1,129	(Z0605)	0.711	1.459	1,223
ZL-H-50120-38-15	(Z0605)	0.688	1.336	1,115	(Z0605)	0.690	1.443	1,207
ZL-H-50120-40-15	(Z0605)	0.663	1.319	1,096	(Z0605)	0.667	1.423	1,186
ZL-H-50120-44-15	(Z0605)	0.629	1.298	1,070	(Z0605)	0.636	1.395	1,156
ZL-H-50120-48-15	(Z0605)	0.604	1.281	1,051	(Z0605)	0.616	1.372	1,132
ZL-H-50120-52-15	(Z0605)	0.585	1.266	1,034	(Z0605)	0.602	1.353	1,111
ZL-H-50120-56-15	(Z0605)	0.572	1.252	1,017	(Z0605)	0.589	1.333	1,091

Passive house-suitable

Passive house-suitable

* Effects of screws per piece 0.00083 W/K, for System 50 mm and with screw spacing of 250 mm = + 0.07 W/(m²·K)
Screw effects according to ebök (12.2008)

TI-H_9.4_002.dwg

U_f values

9.4
4

Determination of the U_f values according to
DIN EN 10077-2

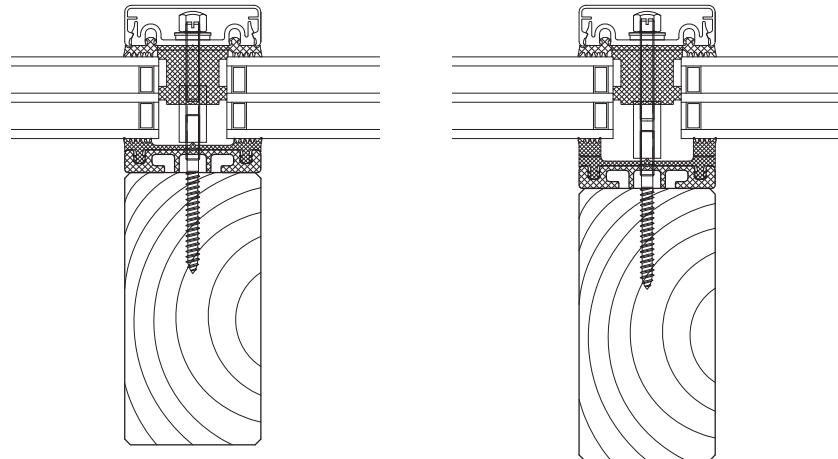

Norden Facade
ZL-H

60120
Glass inset 15

Values without effect
of screws*

System

	5 mm seal				12 mm seal			
	U_f (W/m ² K) with isolator	U_f (W/m ² K) without isolator		U_f (W/m ² K) with isolator	U_f (W/m ² K) without isolator			
Outer seal	GD 1934		GD 6024	GD 1934	GD 1934	GD 6024	GD 1934	
ZL-H-60120-24-15	(Z0608)	0.907	1.527	1,249	(Z0608)	0.912	1.664	1,387
ZL-H-60120-26-15	(Z0608)	0.884	1.517	1,235	(Z0608)	0.892	1.650	1,372
ZL-H-60120-28-15	(Z0608)	0.856	1.498	1,214	(Z0608)	0.871	1.629	1,349
ZL-H-60120-30-15	(Z0608)	0.833	1.482	1,196	(Z0608)	0.853	1.610	1,328
ZL-H-60120-32-15	(Z0608)	0.820	1.473	1,185	(Z0608)	0.844	1.598	1,316
ZL-H-60120-34-15	(Z0608)	0.802	1.460	1,171	(Z0607)	0.711	1.582	1,299
ZL-H-60120-36-15	(Z0608)	0.793	1.451	1,160	(Z0607)	0.690	1.570	1,286
ZL-H-60120-38-15	(Z0607)	0.673	1.441	1,149	(Z0607)	0.672	1.556	1,273
ZL-H-60120-40-15	(Z0607)	0.651	1.427	1,133	(Z0607)	0.653	1.540	1,256
ZL-H-60120-44-15	(Z0607)	0.621	1.410	1,115	(Z0607)	0.626	1.518	1,246
ZL-H-60120-48-15	(Z0607)	0.599	1.396	1,098	(Z0607)	0.609	1.499	1,223
ZL-H-60120-52-15	(Z0607)	0.583	1.383	1,085	(Z0607)	0.599	1.482	1,197
ZL-H-60120-56-15	(Z0607)	0.573	1.372	1,072	(Z0607)	0.589	1.466	1,181

Passive house-suitable

Passive house-suitable

* Effects of screws per piece 0.00083 W/K, for System 60 mm and with screw spacing of 250 mm = + 0.05 W/(m²·K)
Screw effects according to ebök (12.2008)

TI-H_9.4_002.dwg

U_f values

9.4
4

Determination of the U_f values according to
DIN EN 10077-2

Norden Facade ZL-H

60120
Glass inset 20

Values without effect of screws*

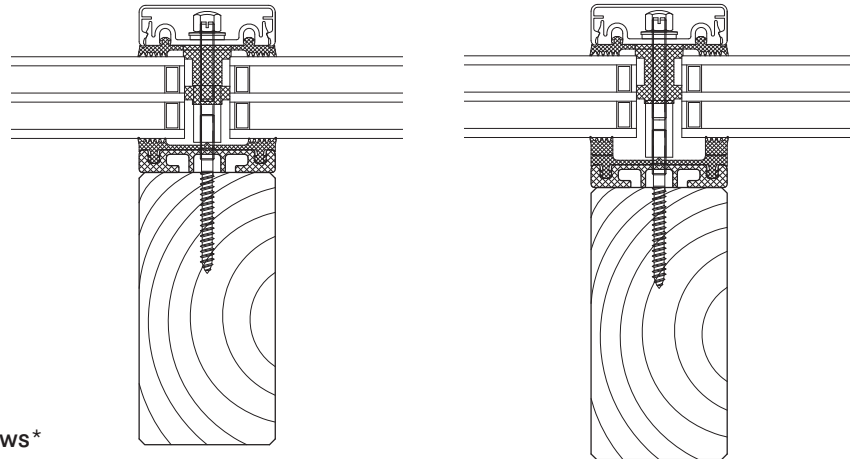

System	5 mm seal			12 mm seal				
	U_f (W/m ² K) with isolator	U_f (W/m ² K) without isolator		U_f (W/m ² K) with isolator	U_f (W/m ² K) without isolator			
Outer seal	GD 1934		GD 6024	GD 1934		GD 6024		
ZL-H-60120-24-20	(Z0606)	0.906	1.282	1,154	(Z0606)	0.910	1.394	1,246
ZL-H-60120-26-20	(Z0606)	0.878	1.261	1,132	(Z0606)	0.884	1.370	1,221
ZL-H-60120-28-20	(Z0606)	0.845	1.234	1,103	(Z0606)	0.855	1.340	1,190
ZL-H-60120-30-20	(Z0606)	0.816	1.209	1,078	(Z0606)	0.830	1.312	1,163
ZL-H-60120-32-20	(Z0606)	0.797	1.193	1,061	(Z0606)	0.815	1.293	1,144
ZL-H-60120-34-20	(Z0606)	0.775	1.173	1,040	(Z0605)	0.716	1.270	1,121
ZL-H-60120-36-20	(Z0606)	0.757	1.157	1,024	(Z0605)	0.695	1.251	1,103
ZL-H-60120-38-20	(Z0605)	0.675	1.140	1,006	(Z0605)	0.674	1.233	1,084
ZL-H-60120-40-20	(Z0605)	0.651	1.122	0,987	(Z0605)	0.651	1.211	1,062
ZL-H-60120-44-20	(Z0605)	0.615	1.095	0,958	(Z0605)	0.620	1.179	1,031
ZL-H-60120-48-20	(Z0605)	0.587	1.071	0,934	(Z0605)	0.595	1.151	1,003
ZL-H-60120-52-20	(Z0605)	0.566	1.051	0,913	(Z0605)	0.578	1.128	0,979
ZL-H-60120-56-20	(Z0605)	0.547	1.033	0,894	(Z0605)	0.562	1.105	0,957

Passive house-suitable

Passive house-suitable

* Effects of screws per piece 0.00083 W/K, for System 60 mm and with screw spacing of 250 mm = + 0.05 W/(m²·K)
Screw effects according to ebök (12.2008)

TI-H_9.4_002.dwg

U_f values

9.4
4

Determination of the U_f values according to
DIN EN 10077-2

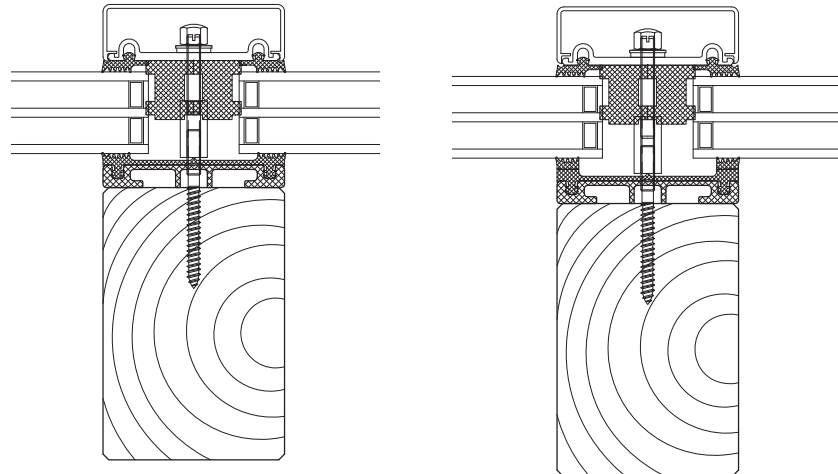

Norden Facade
ZL-H

80120
Glass inset 20

Values without effect
of screws*

System

	5 mm seal			12 mm seal				
	U_f (W/m ² K) with isolator	U_f (W/m ² K) without isolator		U_f (W/m ² K) with isolator	U_f (W/m ² K) without isolator			
Outer seal	GD 1934		GD 8024	GD 1934	GD 8024			
ZL-H-80120-24-20	(Z0606)	0.856	1.385	1,162	(Z0606)	0.867	1.532	1,281
ZL-H-80120-26-20	(Z0606)	0.834	1.374	1,149	(Z0606)	0.849	1.518	1,266
ZL-H-80120-28-20	(Z0606)	0.810	1.358	1,131	(Z0606)	0.828	1.500	1,246
ZL-H-80120-30-20	(Z0606)	0.789	1.344	1,115	(Z0606)	0.810	1.482	1,228
ZL-H-80120-32-20	(Z0606)	0.771	1.335	1,105	(Z0606)	0.801	1.472	1,216
ZL-H-80120-34-20	(Z0606)	0.758	1.324	1,091	(Z0605)	0.679	1.457	1,201
ZL-H-80120-36-20	(Z0606)	0.747	1.316	1,081	(Z0605)	0.661	1.446	1,188
ZL-H-80120-38-20	(Z0605)	0.642	1.306	1,071	(Z0605)	0.645	1.435	1,176
ZL-H-80120-40-20	(Z0605)	0.622	1.294	1,058	(Z0605)	0.627	1.420	1,161
ZL-H-80120-44-20	(Z0605)	0.595	1.278	1,040	(Z0605)	0.603	1.400	1,140
ZL-H-80120-48-20	(Z0605)	0.574	1.264	1,024	(Z0605)	0.587	1.382	1,122
ZL-H-80120-52-20	(Z0605)	0.558	1.253	1,011	(Z0605)	0.574	1.360	1,106
ZL-H-80120-56-20	(Z0605)	0.547	1.241	0,998	(Z0605)	0.565	1.352	1,091

Passive house-suitable

Passive house-suitable

* Effects of screws per piece 0.00083 W/K, for System 80 mm and with screw spacing of 250 mm = + 0.04 W/(m²·K)
Screw effects according to ebök (12.2008)

TI-H_9.4_002.dwg

U_f values

9.4
4

Determination of the U_f values according to
DIN EN 10077-2

Norden Facade AK-H

5090
Glass inset 15

Values without effect of screws*

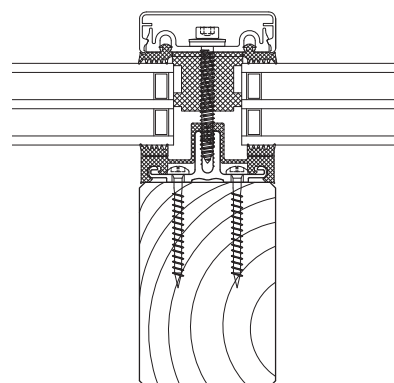

System	16,5 mm seal			
	U_f (W/m ² K) with isolator		U_f (W/m ² K) without isolator	
Outer seal	GD 1934		GD 5024	GD 1934
AK-H-6090-24-15	(Z0609)	1,381	2,230	1,805
AK-H-6090-26-15	(Z0609)	1,386	2,181	1,758
AK-H-6090-28-15	(Z0609)	1,362	2,129	1,705
AK-H-6090-30-15	(Z0606)	1,342	2,082	1,658
AK-H-6090-32-15	(Z0608)	1,010	2,045	1,626
AK-H-6090-34-15	(Z0608)	1,008	2,012	1,590
AK-H-6090-36-15	(Z0608)	0,091	1,979	1,559
AK-H-6090-38-15	(Z0608)	0,976	1,951	1,534
AK-H-6090-40-15	(Z0608)	0,957	1,918	1,503
AK-H-6090-44-15	(Z0608)	0,935	1,870	1,458
AK-H-6090-48-15	(Z0607)	0,690	1,836	1,421
AK-H-6090-52-15	(Z0607)	0,690	1,803	1,391
AK-H-6090-56-15	(Z0607)	0,675	1,774	1,363

* Effects of screws for System 50 mm and with screw spacing of 250 mm = + 0.05 W/(m²·K)
Screw effects according to ebök (12.2008)

TI-H_9.4_002.dwg

U_f values

9.4
4

Determination of the U_f values according to
DIN EN 10077-2

Norden Facade **AK-H**

6090
Glass inset 15

Values without effect of screws*

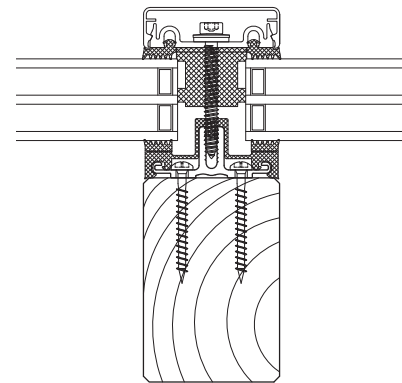

System	16.5 mm seal			
	U_f (W/m ² K) with isolator		U_f (W/m ² K) without isolator	
			GD 6024	GD 1934
Outer seal	GD 1934		GD 6024	GD 1934
AK-H-6090-24-15	(Z0606)	1,314	2,151	1,712
AK-H-6090-26-15	(Z0606)	1,287	2,103	1,665
AK-H-6090-28-15	(Z0606)	1,257	2,051	1,617
AK-H-6090-30-15	(Z0606)	1,003	2,007	1,573
AK-H-6090-32-15	(Z0606)	0,962	1,973	1,542
AK-H-6090-34-15	(Z0606)	0,958	1,938	1,582
AK-H-6090-36-15	(Z0606)	0,941	1,908	1,548
AK-H-6090-38-15	(Z0605)	0,926	1,880	1,516
AK-H-6090-40-15	(Z0605)	0,909	1,850	1,483
AK-H-6090-44-15	(Z0605)	0,886	1,803	1,432
AK-H-6090-48-15	(Z0605)	0,674	1,765	1,390
AK-H-6090-52-15	(Z0605)	0,663	1,734	1,356
AK-H-6090-56-15	(Z0605)	0,648	1,705	1,324

* Effects of screws for System 60 mm and with screw spacing of 250 mm = + 0.05 W/(m²·K)
Screw effects according to ebök (12.2008)

U_f values

9.4
4

Determination of the U_f values according to
DIN EN 10077-2

Norden Facade AK-H

8090
Glass inset 20

Values without effect of screws*

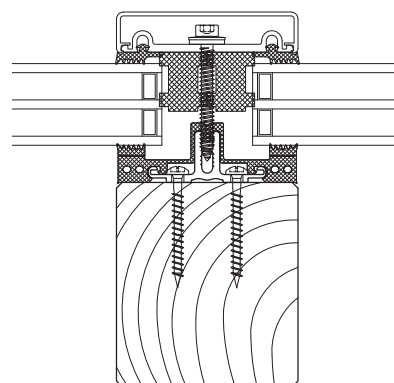

System	16.5 mm seal			
	U_f (W/m ² K) with isolator		U_f (W/m ² K) without isolator	
Outer seal	GD 1934		GD 8024	GD 1934
AK-H-8090-24-20	(Z0606)	1.188	1.886	1,537
AK-H-8090-26-20	(Z0606)	1.161	1.849	1,503
AK-H-8090-28-20	(Z0606)	1.128	1.810	1,464
AK-H-8090-30-20	(Z0606)	0.916	1.774	1,429
AK-H-8090-32-20	(Z0606)	0.886	1.749	1,405
AK-H-8090-34-20	(Z0606)	0.883	1.722	1,374
AK-H-8090-36-20	(Z0606)	0.871	1.698	1,354
AK-H-8090-38-20	(Z0605)	0.857	1.673	1,331
AK-H-8090-40-20	(Z0605)	0.842	1.651	1,306
AK-H-8090-44-20	(Z0605)	0.817	1.611	1,272
AK-H-8090-48-20	(Z0605)	0.632	1.582	1,234
AK-H-8090-52-20	(Z0605)	0.626	1.547	1,214
AK-H-8090-56-20	(Z0605)	0.612	1.529	1,185

* Effects of screws for System 80 mm and with screw spacing of 250 mm = + 0.04 W/(m²·K)
Screw effects according to ebök (12.2008)

TI-H_9.4_002.dwg

Humidity protection in the glass facade

9.5
1

Humidity protection

The highest demands are placed in the design of a modern mullion-transom facade, which can only be satisfied through competent planning and careful execution. The physical task of a structurally intact facade is to create a healthy room climate.

Heat insulation properties and humidity protection are among the most important characteristics of an intact outer shell around a structure. In principle, the following structure is applied in the design of a facade: water-repellent on the outside, sealed on the inside. This allows humidity precipitating on the component to diffuse outwards.

The Norden Facade facade systems softly pack installed elements like panes, panels or opening elements between sealing profiles and then attach them to the mullion-transom construction using clamping strips. The so-called rebate is produced in the clamping area between the installed elements. This rebate must be vapour-proof towards the room and sealed again the penetration of water from the side exposed to the weather. Room-side vapour-proof qualities are mandatory. Warm room air flowing into the rebate can produce condensation as it cools.



It is not possible to explicitly exclude the possibility that

condensation will form in our latitudes. The Norden Facade in-sulation geometries safely transport any damp and condensation that penetrates due to imprecise assembly and changes through temperature fluctuation out of the rebate without it entering the construction.

There must be an opening at the highest and lowest points of the rebate. The opening in the rebate should exhibit a diameter of at least 8 mm and, designed as a slot, should have the dimensions 4 x 20 mm. Insulating glass manufacturers, standards and regulations require there to be a sufficiently ventilated rebate with pressure equalisation openings. This applies also to glazing with sealants, e.g. silicone.

Airtightness is also an important factor in connection with thermal insulation. Heat losses will be lower if the external wall is sealed. Room air exchange and extraction of warm air should take place exclusively through targeted ventilation in window openings and ventilation systems.

The Norden Facade glazing system possesses outstanding sealant properties, as demonstrated in external testing. Norden Facade facade systems are also suitable for the most exposed applications, e.g. on high-rise buildings.

Specifications		Facade	Facades with inclinations	Roof up to 2°
Norden Facade H und Norden Facade ZL-H		5 mm sealing height	up to 20°; overlapping inner sealing	inclination
System widths		50, 60, 80 mm	50, 60, 80 mm	50, 60, 80 mm
	Air permeability EN 12152	AE	AE	AE
	Watertightness EN 12154/ENV 13050	static dynamic RE 1650 Pa 250 Pa/750 Pa	RE 1650 Pa 250 Pa/750 Pa	RE 1350 Pa*

*the test was carried out using a water volume of 3.4 l/(m² min) - above the amount required by the standard

Humidity protection in the glass facade

9.5
1

Terms

Water vapour / condensation

Water vapour is a term used to describe the gaseous aggregate state produced by the evaporation of water. One cubic metre (m³) of air can only absorb a limited quantity of water vapour. The amount rises with the temperature. When air cools, it is no longer able to hold the same quantity of water. The excess water condenses, hence converting from its gaseous to its liquid state. The temperature at which this effect occurs is called the temperature of dew point, or simply the dew point.

When the inside temperature of 20°C with relative humidity of 50% cools to 9.3°C, the relative humidity rises to 100%. Condensation will precipitate if the air or contact surfaces (thermal bridges) continue to cool down. The air is no longer able to absorb the water in the form of water vapour.

Relative humidity f

The maximum volume of water vapour is rarely encountered in practice. Merely a certain percentage is reached. This is known as relative humidity, which is also temperature-dependent. It rises when the temperature falls and falls when the temperature rises, with otherwise constant levels of moisture.

Example:

A mixture of water vapour and air of 1 m³ at 0°C has a relative humidity of 100% if it contains 4.9 g of water. A reduction in relative humidity occurs if the temperature rises, for instance to 20°C, if water absorption does not increase. At this temperature, an atmosphere with 100% relative humidity would be able to hold no more than 17.3 g, so 12.4 g more, of water. But given that additional moisture is not added, the 4.9 g of moisture contained in the cold air would now represent relative humidity of 28%.

Water vapour pressure

Besides relative humidity, the prevalent pressure is another important factor in the diffusion process. The water vapour produces pressure that rises with the volume of water vapour contained in the air. The conditions for water molecules to condensate will be more favourable if the water vapour saturation pressure is exceeded, hence lowering the pressure.

Water vapour diffusion

Water vapour diffusion describes the proper motion of water vapour through construction materials. Variations in water vapour pressures on either side of the component trigger this mechanism. The water vapour held in the air migrates from the side with the higher pressure toward the side with the lower vapour pressure. Here, the water vapour pressure depends on the temperature and the relative humidity.

Important: A vapour block (e.g. metal foil) and similar installations can entirely prevent the transport of water vapour through the material, but they cannot stop the passage of heat!

Water vapour diffusion resistance coefficient μ

The quotient of the water vapour diffusion transfer coefficient in the air and the water vapour diffusion transfer coefficient in a substance. It therefore expresses the factor by which the water vapour diffusion resistance of the considered material is greater than that of the layer of air in the same thickness and temperature resting on the material. The water vapour diffusion resistance coefficient is a material property.*

Thickness of the air layer equivalent to the water vapour diffusion s_d

Thickness of a resting layer of air possessing the same water vapour diffusion resistance as the considered construction component, i.e. the component comprising several layers. It determines the resistance to water vapour diffusion. The thickness of the air layer equivalent to the water vapour diffusion is a layer, i.e. component property. It is defined for a component layer using the following formula:

$$s_d = \mu \cdot d^*$$

* Excerpt from DIN 4180-3

Humidity protection in the glass facade

9.5
1

The water vapour is unable to diffuse evenly through all components. Hence the fall in pressure is not the same across the entire wall cross-section. The fall in pressure is large in impermeable materials and small in permeable materials. This phenomenon is precisely what the dimensionless water vapour diffusion resistance coefficient μ describes: The water vapour diffusion resistance of a material is μ times larger than the resting layer of air. So an air layer requiring the same diffusion resistance as the material would have to be μ times thicker than the material layer. The water vapour diffusion resistance coefficient μ is a material property and independent of the size (thickness) of the material. An example: The diffusion resistance of a layer of cellulose flakes with $\mu=2$ and a thickness of 0.1 m is equivalent to an air layer with a thickness of $2 \times 10 \text{ cm} = 0.2 \text{ m}$. This “diffusion-equivalent air layer thickness”, calculated using μ , is known as the S_d value. In other words: The S_d value of a component describes how thick the air layer resting on the component would have to be (in metres) to possess an equal diffusion resistance as the component. The S_d value is therefore a component-specific property and depends on the type of construction component and its thickness.

Temperature factor f_{Rsi}

Used to determine the freedom of fungal growth on window connections.

The temperature factor f_{Rsi} is the difference between the temperature of the inside surface θ_{si} of a component and the outside air temperature θ_e , relative to the temperature difference between the inside θ_i and outside air θ_e .

A variety of requirements must be adhered to in order to introduce design measures to reduce the risk of fungal growth. For instance, for all constructive, shape-related and material-related thermal bridges that deviate from DIN 4108-2, the temperature factor f_{Rsi} at the least favourable point must satisfy the minimum requirement of $f_{Rsi} \geq 0.70$:

Water vapour convection

Transfer of water vapour in a gaseous mixture by movements of the gaseous mixture as a whole, e.g. moist air, caused by the overall pressure gradient. Overall pressure gradients can occur, for instance, due to circumferential flow in the building through joints and leakages between inner rooms and their environments, or between ventilated layers of air (forced convection), i.e. due to differences in temperature and hence air density in ventilated and non-ventilated layers of air (free convection)*

Regulations

- DIN 4108 Thermal protection and energy economy in buildings
- DIN 4108-3 Protection against moisture subject to climate conditions; Requirements and directions for design and construction
- DIN 4108-4 Hygrothermal design values
- DIN 4108-7 Airtightness of building, requirements, recommendations and examples for planning
- DIN 18361 Glazing work (VOB Part C)
- DIN 18360 Metal work (VOB Part C)
- DIN 18545 Sealing of glazing with sealants
- Energy Saving Ordinance (EnEV)
- EnEV Validation of thermal bridges
- DIN EN ISO 10211: Thermal bridges in building construction
- Passive house standard
- DIN EN ISO Thermal and moisture behaviour of construction materials and products
- DIN EN 12086 Thermal insulating products for building applications - Determination of water vapour transmission properties

* Excerpt from DIN 4180-3

Humidity protection in the glass facade

9.5
1

General requirements for glass constructions

A glass construction that separates climates must transport the diffusing water vapour from the inside to the outside. This process should not produce condensation when possible. The wall must be permeable for diffusion travelling from the inside to the outside. This requires the following individual measures:

1. An inner sealing section with the greatest possible vapour diffusion resistance.
2. An outer sealing section with the lowest possible vapour diffusion resistance.
3. A suitable design of the rebates to enable convective removal of moisture.
4. Also a suitable design of the rebates to enable targeted removal of condensation.
5. Diffusion channel control also in the area connecting with the adjacent structure.

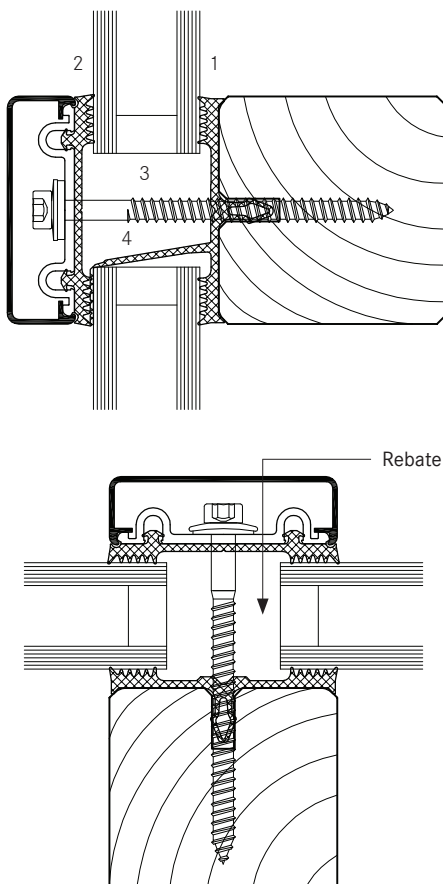

Important notes:

Experience has shown that absolute water and vapour imperviousness is not possible in a mullion-transom structure. Imprecise assembly of the sealant sections to the building connections may be possible sources of moisture damage. This may allow moisture to act directly on the room-side surfaces of thermal bridges and hence lead to the formation of condensation. In addition, damage may also be caused by the direct effects of moisture and elevated vapour pressure in the rebate with negative implications for the edge bonding of the inset elements. Water vapour may then penetrate the area between the panes.

Example: Leaks in profile surfaces may cause 20 litres of water to precipitate on an element measuring 1.35 (b) x 3.5 (h) during a dew period lasting 60 days.

It is essential to ensure that the rebate is produced precisely in order to prevent damage in the long term. This enables to rapid and unobstructed removal of moisture caused by precipitation and dew. Slab insulation must not prevent effective ventilation of the rebate! The slab insulation must be selected such that there is a gap of at least 10 mm to the lower edge of the rebate in order to provide ventilation and to extract condensation.

The edge bonding with the glazing must be selected carefully in order to prevent thermal bridges on profiles that may cause condensation and above all fungal growth in the hollow cavities. A favourable U_f value* for the profile is not sufficient on its own to guarantee the absence of dew. The ψ value* may be equally crucial. This depends on the type of edge bonding. Aluminium edge bonding is the least favourable. Therefore, the absence of dew must be checked when aluminium edge bonding is used. This applies in particular when the facade is adjacent to rooms with high humidity, e.g. bathrooms.

Humidity protection in the glass facade

9.5
1

Inner sealing section

Construction materials are vapour-proof according to DIN EN 12086, i.e. DIN EN ISO 12572, if they exhibit an air layer thickness equivalent to water vapour diffusion of S_d von ≥ 1500 m. Standard glazing sealants are unable to provide these values. Nevertheless, the layer inhibiting diffusion can be considered adequate for the application described here if it accommodates layer thicknesses S_d of ≥ 30 m. In order to determine the air layer thickness equivalent to water vapour diffusion S_d , it is necessary to obtain the water vapour diffusion resistance coefficient μ and the component thickness.

Abutted points on seals are comparably impermeable as the entire sealant cross-section, provided they are glued using the "SG joint paste" recommended by Norden Facade. Vapour-proof connections with the structure must be positioned as far away from the room side as possible in order to prevent moisture penetrating the structure. (See Fig. 1) Additional film on the weather side (i.e., an external 2nd film) may only be used if driving rain or rising water cannot be kept out by other means. Vapour-permeable films must be used in this context. Layer thicknesses S_d of no more than 3 m shall be considered vapour-permeable for our constructions.

The following table shows several examples of materials.

Material	Gross density kg/m ³	μ - Water vapour diffusion coefficient	
		Dry	Damp
Air	1.23	1	1
Plaster	600-1500	10	4
Concrete	1800	100	60
Metal/glass	-	∞	∞
Mineral wool	10-200	1	1
Timber	500	50	20
Polystyrene	1050	100000	100000
Butyl rubber	1200	200000	200000
EPDM	1400	11000	11000

μ - is a value stated without dimensions. The higher the μ value, the greater the vapour-proof properties of the substance. It is multiplied with the thickness of the construction material to produce the component-based value $S_d = \mu \cdot d$

Outer sealing sections

The primary purpose of the external sealant is to keep out driving rain. Nevertheless, it is essential to ensure that convection openings provide a diffusion gradient from the inside to the outside. (See Fig. 2 and 3)

Convection flow

The rebates in Norden Facade mullion-transom constructions are always ventilated. Ventilation is ensured by openings in the lower and upper ends in the area of the mullions. These openings, which are produced by design, must be impervious to driving rain. The horizontal rebates are ventilated via the connections in the cross joints, i.e. openings in the cover strips. Should additional ventilation be required in the area of the transom (e.g. where panes are only supported on 2 sides or where transom length is $l \geq 2$ m), then this ventilation should be created by making holes in the cover strip and/or using notches on the lower sealing lips of the outer seal.

The S_d value of a component describes how thick the air layer resting on the component would have to be (in metres) to possess diffusion resistance equal to the component.

Humidity protection in the glass facade

9.5
1

Design details

Fig. 1 Horizontal wall connection

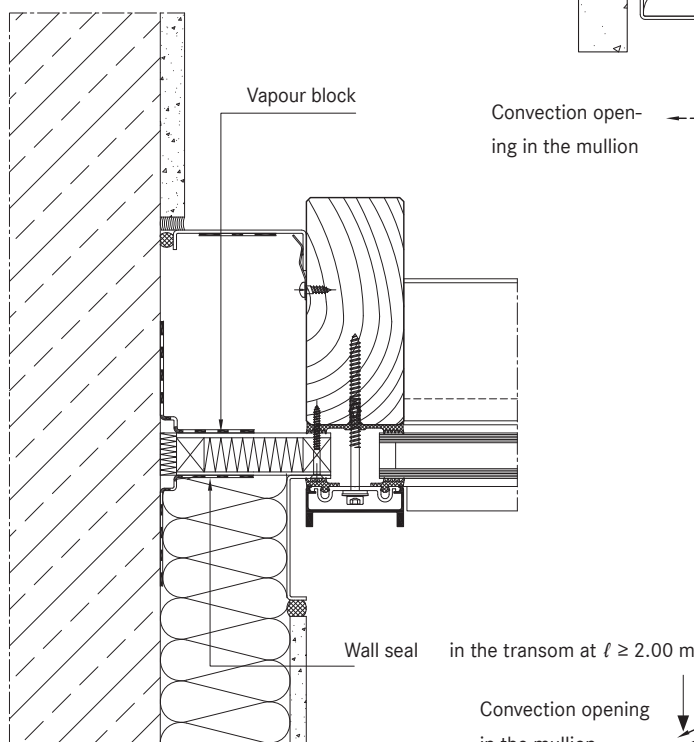

TI-H_9.5_001.dwg

Fig. 2 Ceiling connection

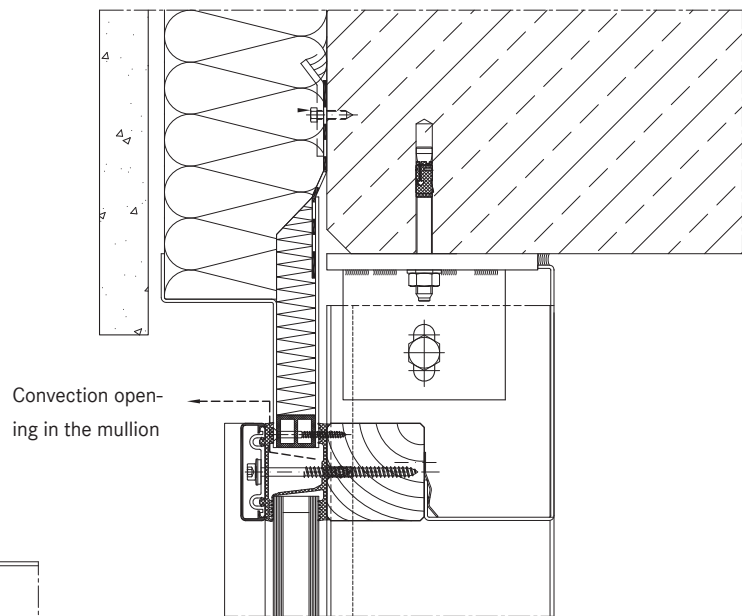
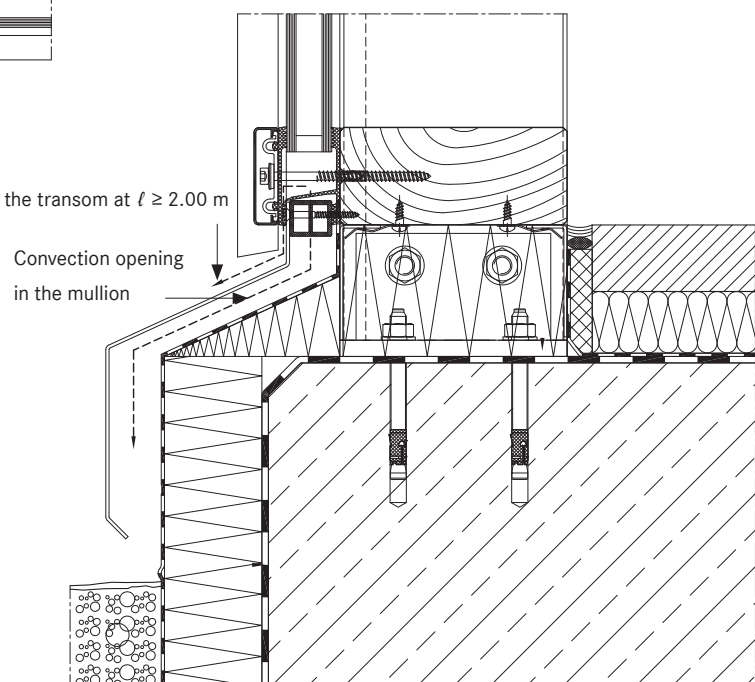

Fig. 3 Foot



TI-H_9.5_002.dwg

Humidity protection in the glass facade

9.5
1

Particular factors of the timber system

Condensation and fungal growth

Untreated timber is susceptible to fungal infestation, depending on the temperature and humidity. Cellulose decomposition leads to a destruction of the cell walls and hence to a reduction in strength. Moreover, organic decomposition processes are accompanied by staining and the development of odours.

In order to prevent these processes, it is important to stop the occurrence of any conditions that may lead to condensation or fungal growth in the timber.

Moisture concentration in timber

Extensive testing was conducted to ascertain the actual moisture concentration on the inside of load-bearing facade profiles, even under the most extreme conditions. In this respect we refer to the findings of the research by ift Rosenheim and others.

The results of these measurements were used to assessed by thermal flow analysis to determine the dam-aging moisture concentration for Norden Facade systems. As the research report mentions, the extremely unfavourable conditions, which under normal circumstances would never occur, were also applied to extremely unfavourable solid wood profiles made of untreated softwood.

The facade profiles were exposed to different climates on either side over approximately 60 days. The climate on the room side was 23°C and 50% humidity, while the climate on the outside was -10°C.

An assessment of the findings permits the conclusion that the maximum core moisture content in the cross-sections equivalent to Norden Facade profiles with direct screw fittings reached 17%. Norden Facade systems with direct screw fittings have a clamping groove to accommodate the seal in the area affected by the highest moisture concentration; the research findings ascertain that it can be considered a relief groove.

Emergence of condensation on the threaded surfaces of the fixing screws

It is necessary to prove that under the aforementioned conditions and with the ascertained findings, condensation does not form, not even marginally, on the inserted screws that are exposed to the extreme cold of the outside climate. To do this, we calculated the surface temperatures of the threaded pins due to heat conduction and hence determined the absence of condensation. This calculation considered the complicating aspect that, as stated in relevant literature, fungal growth may occur from a saturation of 75%.

With due consideration of the extreme stress described above, and in anticipation of more favourable ambient conditions to promote fungal growth, the validation provided hereunder demonstrates that an impairment of the strength and durability cannot occur due to the direct screw fittings.

Validation for absence of condensation

Condensation begins to form on the extremely cooled screw surfaces if the water vapour saturation pressure on the surface of the screw ($P_{s,oi}$) \leq the water vapour saturation pressure of the surrounding timber (P_s, H), multiplied by the measured timber moisture. Converted into the moisture content from which condensation will form, the calculation is therefore:

$$\begin{aligned} P_{s,oi} \text{ for } -4.8^\circ\text{C} &= 408 \text{ pa} \\ P_{s,Hi} \text{ for } 10^\circ\text{C} &= 1228 \text{ pa} \end{aligned}$$

This means that condensation will precipitate on the screw surface from a moisture content of 33%. The maximum measured values are 17%. This ensures that damaging condensation will not emerge in the area of the screw fittings.

No fungal growth

Fungal growth any permanent damage of the timber occurs from a saturation level of 75%. The measured maximum values of 17% are still significantly below the 25% (approx. 75% of the condensation precipitation limit) at which there is a risk of fungal growth. The permanent function of the Norden Facade direct screw fittings is therefore validated.

Humidity protection in the glass facade

9.5
1

Dew point temperature depending on the temperature and relative humidity (excerpt from DIN 4108-5 Table 1)

Air temperature in C°	Dew point temperature θ_s in C° at relative humidity as a % of														
	30	35	40	45	50	55	60	65	70	75	80	85	90	95	100
30	10.5	12.9	14.9	16.8	18.4	20.0	21.4	22.7	23.9	25.1	26.2	27.2	28.2	29.1	30.0
29	9.7	12.0	14.0	15.9	17.5	19.0	20.4	21.7	23.0	24.1	25.2	26.2	27.2	28.1	29.0
28	8.8	11.1	13.1	15.0	16.6	18.1	19.5	20.8	22.0	23.2	24.2	25.2	26.2	27.1	28.0
27	8.0	10.2	12.2	14.1	15.7	17.2	18.6	19.9	21.1	22.2	23.3	24.3	25.2	26.1	27.0
26	7.1	9.4	11.4	13.2	14.8	16.3	17.6	18.9	20.1	21.2	22.3	23.3	24.2	25.1	26.0
25	6.2	8.5	10.5	12.2	13.9	15.3	16.7	18.0	19.1	20.3	21.3	22.3	23.2	24.1	25.0
24	5.4	7.6	9.6	11.3	12.9	14.4	15.8	17.0	18.2	19.3	20.3	21.3	22.3	23.1	24.0
23	4.5	6.7	8.7	10.4	12.0	13.5	14.8	16.1	17.2	18.3	19.4	20.3	21.3	22.2	23.0
22	3.6	5.9	7.8	9.5	11.1	12.5	13.9	15.1	16.3	17.4	18.4	19.4	20.3	21.2	22.0
21	2.8	5.0	6.9	8.6	10.2	11.6	12.9	14.2	15.3	16.4	17.4	18.4	19.3	20.2	21.0
20	1.9	4.1	6.0	7.7	9.3	10.7	12.0	13.2	14.4	15.4	16.4	17.4	18.3	19.2	20.0
19	1.0	3.2	5.1	6.8	8.3	9.8	11.1	12.3	13.4	14.5	15.5	16.4	17.3	18.2	19.0
18	0.2	2.3	4.2	5.9	7.4	8.8	10.1	11.3	12.5	13.5	14.5	15.5	16.3	17.2	18.0

¹⁾ Approximate linear interpolation is permitted

Sound insulation in the glass facade

9.6
1

Sound insulation

The noise insulating properties of a facade depend on a variety of factors, each of which affects the properties in a different way. Unfortunately it is not possible to summarise these complex interdependencies in simple and universally valid forms. The task of the planner is to expertly select the optimum design on a case-by-case basis. Different combinations of frame profiles, glazing strips and sound insulating glass have vastly different effects on noise insulation. Investigations and measurements performed by us are just examples of a huge range of possibilities and serve only as a guideline. The material selection and cross-sections must be discussed with specialists if higher sound insulation levels are required.

Terms

Sound insulation

Measures to reduce noise transmission from a source to a person. Sound insulation is the term used if the source of noise and the person are located in different rooms. Sound absorption is used if the source of noise and the person are located in the same room. Sound insulation distinguishes between airborne sound insulation and structure-borne sound insulation.

Airborne sound insulation

Airborne sound insulation describes the process of preventing the penetration of outside noise. Airborne noise mainly travels into the room through walls, ceilings, windows and doors.

Structure-borne sound insulation

Structure-borne sound insulation is sound insulation within the building. Structure-borne sound is mainly transmitted by pipes, footfall or circumferential facade mullions.



Noise source
(e.g. street noise)

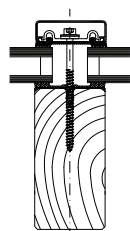

Sound-insulating
component



Receiver

Regulations

DIN 4109, sound insulation in buildings, regulates the matters pertaining to sound insulation under public law. The sound insulation classes described in VDI Guideline 2719, sound insulation of windows and additional fixtures, are often used as well. The measurement of sound insulation in buildings and of components takes place according to DIN EN ISO 717-1. We refer to ongoing harmonisation of European standards and possible changes.

Airborne sound insulation

Airborne sound insulation is the capability of a component (wall, ceiling or window) to prevent the penetration of airborne sound. It is therefore expressed in the unit decibels [dB], referring to the degree of sound insulation R and the sound level difference D in a defined frequency range.

Sound insulation degree R [dB]

This value describes the sound insulation of components. The measurement is performed in a laboratory setting according to EN ISO 140. It determines the acoustic properties for each one-third octave band between 100 and 3150 Hz (16 values).

Assessed sound insulation level R_w [dB]

The assessed sound insulation level R_w is used to determine the sound insulation of glass facades.

$R_{w,R}$ values: This index weights the 16 measured values of the sound insulation level R in terms of their impact on the human ear. Here, $R_{w,P}$ is the value determined in the laboratory testing. DIN 4109 demands that the calculated value $R_{w,R} = R_{w,P} - 2$ db is determined and entered in the Construction Components List.

R'_w values: According to DIN 52210, they are sound insulation values determined for the building.

For building certification, the minimum values for overall sound insulation may be exceeded by 5 dB.

Sound insulation in the glass facade

9.6
1

Spectrum adjustment values C and C_{tr}
These indices are corrective values for

(C) Pink noise = same sound level across the entire frequency spectrum;

(C_{tr}) Street noise = standardised urban street noise.

System Norden Facade H

The tests we commissioned from the independent test institute ift-Rosenheim are intended to provide an overview of the sound insulation characteristics that Norden Facade system facades exhibit. The tests are performed on large facade elements with standard grids. Measurements were performed using a variety of sound insulation glazings in accordance with the standard sound insulation requirements.

- Standard insulation glass (6 / 12 air / 6)

- Insulation glass (8 / 16 gas filling / 6)

- Insulation glass (9 GH / 16 gas filling / 6)

The gas filling in the glazing was approx. 65% argon and approx. 35% SF6. The panes can no longer be installed due to the use of SF6.

It is not mandatory that the system manufacturer uses these glass types. Equivalent sound insulation values can be achieved with other sound insulation glazing.

The following table shows the sound insulation characteristics of the facades. The complexity of individual construction projects means that a precise assessment by experts and possibly measurements on the ground will usually be required.

We are glad to provide our individual test reports as required.

Profile structure		Glass structure Interior/SZR/interior	assessed sound insulation level R_w		Class according to VDI	Test report by ift Rosenheim
vertical (mullion)	horizontal (transom)		Test value $R_{w,P}$	Calculated value $R_{w,R}$		
mm	mm		dB	dB		
60 x 120	60 x 60	6 / 12 / 6 air	34	32	2	161 18611 / 1.0.0
60 x 120	60 x 60	8 / 16 / 6 gas filling	38	36	3	161 18611 / 1.1.0
60 x 120	60 x 60	9GH / 16 / 6 gas filling	41	39	3	161 18611 / 1.2.0

Sound insulation class according to VDI Regulation 2719	Assessed sound insulation dimension R_w of the working glazing installed in the building, measured according to DIN 52210 Part 5	Required assessed sound insulation dimension $R_{w,P}$ of the working glazing installed on the test rig according to DIN 52210 Part 2
	dB	dB
1	25 to 29	≤ 27
2	30 to 34	≥ 32
3	35 to 39	≥ 37
4	40 to 44	≥ 42
5	45 to 49	≥ 47
6	> 50	≥ 52

Sound insulation in the glass facade

9.6
1

Sound measurement curves in the laboratory testing

Test by ift Rosenheim
Test report no. 161 18611/1.0.0

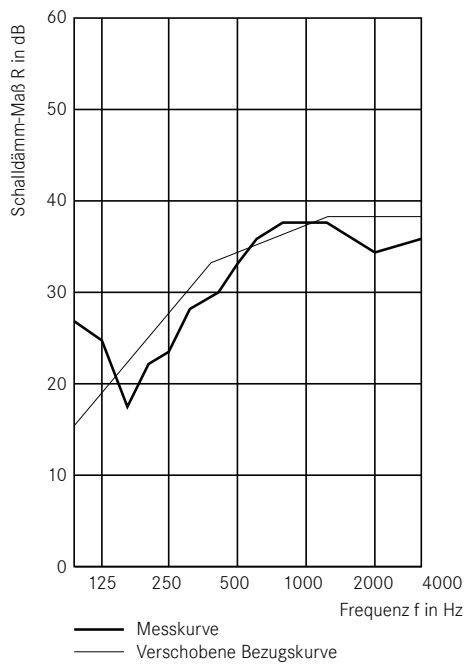

Test by ift Rosenheim
Test report no. 161 18611/1.1.0

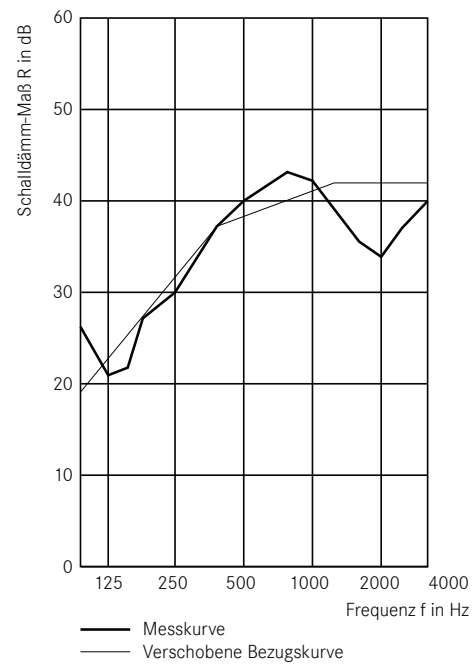

Test by ift Rosenheim
Test report no. 161 18611/1.2.0

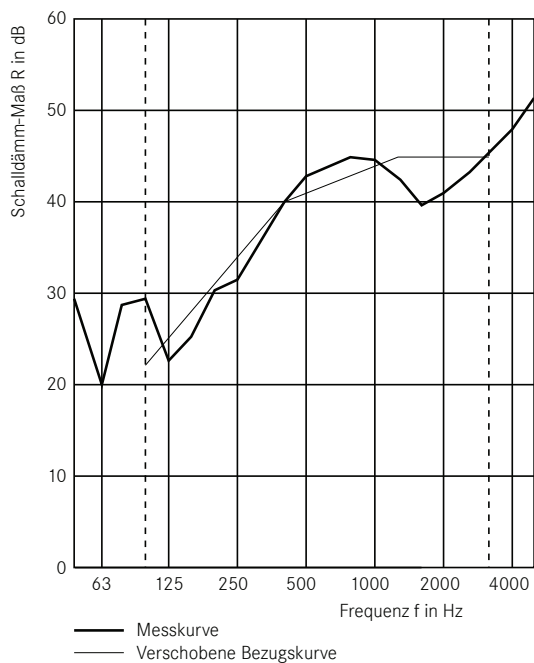

Overview

9.7
1

Fire protection glazing for facades

The development of Norden Facade glazing into fire-resistant systems primarily addressed technical requirements relating to fire resistance. A secondary aspect was to create filigree and economic solutions. Tests at the competent institutes and the general building authorisations by

Deutsches Institut für Bautechnik (DIBt) allow the use of Norden Facade fire-resistance glazing in Germany. Its installation elsewhere in Europe must be clarified on a case-by-case basis.

Overview of fire protection approvals

System	Class	Application	Glass type	Maximum glass dimensions in portrait format	Maximum glass dimensions in landscape format	Filling, maximum dimensions	Roof dimensions / maximum height	Country	Approval Number
				mm x mm	mm x mm	mm x mm	m		
Norden Facade System H	G 30	Facade	Pyrodur	1210 x 2010	2000 x 1210	1000 x 2000 2000 x 1000	4.50	D	Z-19.14-1283
	F 30	Facade	Pyrostop	1350 x 2350	1960 x 1350	-	4.50	D	Z-19.14-1280
	F 30	Facade	Promaglas	1350 x 2350	1960 x 1350	-	4.50		Z-19.14-1280
	F 30	Facade	Contraflam	1500 x 2300	2300 x 1500	-	4.50	D	Z-19.14-1280

System Norden Facade H in fire protection

The constructive details are stated in the respective building authorisation.

As a rule, Norden Facade fire-resistance glazing provides the following benefits:

- The optical appearance of a normal facade is preserved.

- The use of a stainless steel bottom strip with concealed screw fittings enables the installation of all clipped upper screws.
- The test of stainless steel cover strips also allows visible screw fittings.
- Norden Facade system H preserves all of the benefits of a design and assembly with direct screw fittings.

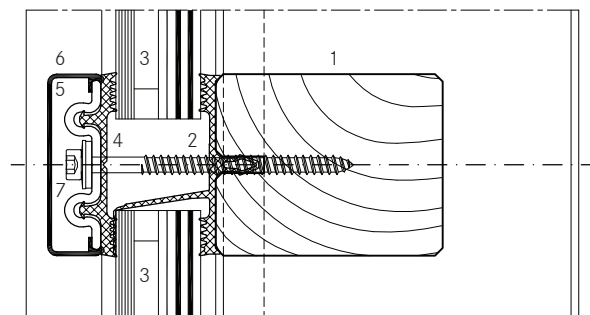
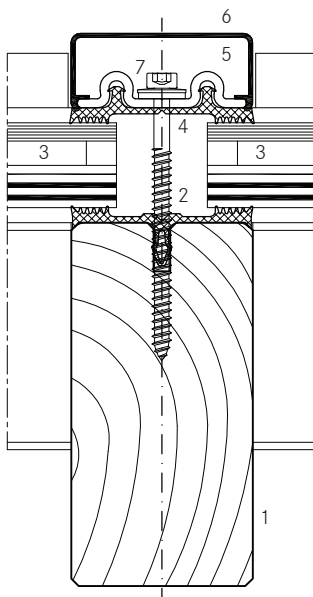

- 1 Timber profiles
- 2 Fire seals inside
- 3 Fire protection glass
- 4 Fire seals outside
- 5 Stainless steel bottom strip
- 6 Upper strip
- 7 Screw fittings

Construction law / Standardisation

9.7
2

Structural fire protection according to the Federal State Building Order

The German constitution or Basic Law assigns the building code to the competencies of the federal states, and not to national government. Provisions concerning preventative fire protection in structures are therefore governed under the Federal State Building Order, the corresponding implementing provisions and a series of regulations and administrative ordinances.

Fire-resistant glazing is based on the following requirements of the General Building Order (MBO):

General requirements – Sec. 3 (1)

Structures must be arranged, constructed, modified and maintained such that they do not endanger public order and safety, in particular the life, limb and natural foundations of life.

Fire protection – Sec. 14

Structures must be arranged, constructed, modified and maintained such that the emergence of fire and the spread of fire and smoke (fire spread) are prevented and that the rescue of persons and animals and effective efforts to extinguish the fire are enabled.

The core statements can be taken to infer requirements for:

- the flammability of the construction materials used;
- the duration of fire resistance based on classifications for construction materials and components;
- the imperviousness of covers on openings;
- the arrangement, location and design of emergency exits.

Basics and requirements

Fire protection in buildings means the protection of life and limb and of commercial assets. Therefore, the manufacture and marketing of technical systems for fire protection requires sufficient expertise.

The following elaborations are intended to assist in the understanding of regulations applicable on the territory of the Federal Republic of Germany and how they re-

late to the current implementation regulations and the national German standard DIN 4102 “Fire behaviour of building materials and building components” in the area of fire-resistant glazing. Terms and definitions used in the harmonised series of European standards DIN EN 13501 “Fire classification of construction products and building elements” are also explained. This standard, as well as various other test standards (e.g. DIN EN 1364), now provide European provisions for the characterisation of the fire behaviour of construction materials (construction products) and components (types) and the definition of terms and tests. However, the European standards differ in places from the German DIN 4102 series, sometimes even substantially. It is therefore to be expected that the German and European classifications will continue to co-exist as valid standards for some time to come.

The regulations under construction laws place demands in the fire behaviour of building materials and components. Intended as technical regulations within construction, the standards define these individual terms used in construction laws more precisely. They contain the conditions for assigning a construction material to a certain classification according to its fire behaviour, and what this classification will be called. Moreover, they explain the test arrangements for components and how they are classified in fire-resistance classes.

Technical classification of the components (construction types) in fire resistance classes according to DIN 4102, i.e. DIN EN 13501

According to DIN 4102-1, construction materials are assigned to the classes A (A1, A2 - not combustible) and B (flammable), with a further distinction in B1 for not easily flammable, B2 for flammable and B3 for easily flammable, depending on their fire behaviour. It is always prohibited to use easily flammable construction materials. It is also important to bear in mind that the fire behaviour when installed is authoritative. For instance, a roll of wallpaper is easily flammable, but not easy to set on fire when it is stuck to the wall.

In contrast, the European standard DIN EN 13501-1 assigns construction materials, i.e. products, to seven

Construction law / Standardisation

9.7
2

classes (A1, A2, B, C, D, E and F). The European standard also defines smoke development (s = smoke) and dripping while burning (d = droplets) as additional test and classification characteristics. The three characteristics are further assigned to three grades:

Smoke development s

- s1: no/hardly any smoke development
- s2: limited smoke development
- s3: unlimited smoke development

Flaming droplets d

- d0: no dripping
- d1: no sustained dripping
- d2: significant dripping

The following table shows the construction material classes according to DIN 4102-1 and DIN EN 13501-1 in a direct comparison. This comparison reveals another important aspect, namely that the classes according to the German/European standards are not entirely equivalent due to the different/additional test procedures.

Table 1: Allocation to classes according to the fire behaviour of construction materials / products (without flooring) according to DIN 4102-1, i.e. DIN EN 13501-1

Building inspectorate requirements	European class according to DIN EN 13501-1	German class according to DIN 4102-1	Nordenproducts according to DIN 4102
"No flammability"	A1	A1	SR, AL, AK, Screws, Cover strips
	A2	A2	
"Low flammability"	B, C	B1	Cross bars, wooden cylinder
	A2, B, C		
	A2, B, C		
	A2, B, C		
	A2, B, C		
"Normal flammability"	D	B2	H*, seals*, Insulating blocks
	E		
	D		
	E		
"High flammability"	F	B3	ZL

*higher building material classes possible

Construction law / Standardisation

9.7
2

Technical classification of the components (construction types) in fire resistance classes according to DIN 4102 or DIN EN 13501

- German standard DIN 4102

The fire resistance classes of components, i.e. construction elements, are defined according to their fire behaviour. This is based on components fire tests according to DIN 4102-2 or other part of the 4102 standard.

Three items of information are used to describe the fire behaviour:

- The letter describes the type of classified component; for instance, “F” stands for supporting and space-enclosing components that are required to satisfy particular requirements in terms of fire resistance. They include walls, ceilings, struts, joists, stairwells and such like. “F” also stands for non-supporting interior walls.
- A number then states the duration of fire resistance. The various gradations (30, 60, 90, 120 and 180) specify the minimum duration in minutes during which a component must satisfy the defined requirements in a fire test.
- In addition to these classifications, DIN 4102 has another indicator to describe the fire behaviour of the main construction materials used in the component.

- A The component consists exclusively of non-combustible construction materials.
- AB All of the essential parts of the component consist of construction materials belonging to class A; construction materials in class B can be used otherwise.
- B Essential parts of the component consists of flammable materials.

These three items of information produce the fire-resistance classes for components as defined in DIN 4102-2. The adjacent table shows the classification, the short name and a comparison of the “building inspectorate requirements”.

Table 2:

Fire resistance classes of components according to DIN 4102-2 and their relevance under building inspectorate requirements (excerpt from DIN 4102-2, Tab. 2)

Building inspectorate requirements	Fire resistance class according to DIN 4102-2	Short description according to DIN 4102-2
Fire-retardant	Fire resistance class F 30	F 30-B
	Fire resistance class F 30 and mainly composed of “non-combustible” construction materials	F 30-AB
Fire-retardant and composed of “non-combustible” construction materials	Fire resistance class F 30 and composed of “non-combustible” construction materials	F 30
	Fire resistance class F 60 and mainly composed of “non-combustible” construction materials	F 60-AB
Highly fire-retardant	Fire resistance class F 60 and composed of “non-combustible” construction materials	F 60
	Fire resistance class F 90 and mainly composed of “non-combustible” construction materials	F 90-AB
Not easily flammable	Fire resistance class F 90 and composed of “non-combustible” construction materials	F 90-A
	Fire resistance class F 120 and composed of “non-combustible” construction materials	F 120-A
	Fire resistance class F 180 and composed of “non-combustible” construction materials	F 180-A

Classification of special components according to DIN 4102:

Some sections of DIN 4102 define requirements and tests for special components that also specify certain fire resistance classes. They include, in particular:

DIN EN 4102	Component	Fire resistance class
Part 3	External wall elements	W30 TO W180
Part 5	Fire barriers	T30 TO T180
Part 6	Ventilation lines and flaps	L30 TO L120
Part 9	Cable fire shields	S30 TO S180
Part 11	Pipe cladding and pipe firestops, installation shafts and barriers in their inspection openings	R30 TO R120
		I30 TO I 120
Part 12	System integrity of electrical cables	E30 TO E90
Part 13	Fire resistant glazing	G30 TO G120
	G glazing F glazing	F30 TO I 120

Construction law / Standardisation

9.7
2

European standard DIN EN 13051

Similar to the classification of fire behaviour for construction materials/construction products, the classification of fire behaviour for construction components/construction types according to the European standard DIN EN 13051, Parts 1 and 2, is more complex than in the German standard DIN 4102.

- It applies an equivalent method of letters and numbers to indicate the classification. Again the numbers indicate the duration of fire resistance in minutes, whereby the European classification system considers more intervals of time (20, 30, 45, 60, 90, 120 180 and 240 minutes).
- The letters describe the assessment criteria based on the type of component. But there is no indication for the essential construction materials used in the component.
- Other groups of letters provide additional information to describe the classification criteria.

Table 3: European classification criteria for the fire resistance of components, i.e. designs according to DIN EN 13501 (excerpt)

Abbreviation	Criterion	Application
R (Resistance)	Carrying capacity	
E (Etancheite)	Protective barrier	
I (Isolation)	Thermal insulation (when exposed to fire)	to describe the fire resistance capability
W (Radiation)	Limitation in heat transmission	
M (Mechanical)	Mechanical effects on the walls (impact stress)	
S (Smoke)	Limitation in smoke permeability (density, leakage rate)	Smoke protection doors (as additional requirement, also for fire barriers), ventilation systems, including flaps
C (Closing)	Self-closing property (with number of load cycles), including permanent function	Smoke protection doors, fire barriers (including barriers for transport systems)
P	Maintenance of power supply and/or signal transmission	Electrical cable systems in general
K1, K2	Fire protection capacity	Wall and ceiling panelling (fire protection panelling)
I1, I2	Different thermal insulation criteria	Fire barriers (including barriers for transport systems)
i → o i ← o i ↔ o (in-out)	Direction of the fire resistance duration	Non-supporting outside walls, installation shafts/ducts Ventilation systems, i.e. flaps
a ↔ b (above-below)	Direction of the fire resistance duration	Suspended ceilings
v _e h _o vertical, horizontal)	Classified for vertical/horizontal installation	Ventilation lines/flaps

Construction law / Standardisation

9.7
2

Combined with the type of component, the fire resistance duration and additional data, there is now a broad variety of European fire resistance classes that did not exist at the time of the national classification system.

Table 4 lists a selection of components with their assigned fire-resistance classes according to DIN EN 13501, Parts 2 and 3. The first column refers to the building inspectorate requirements that are based on the provisions set forth in the Federal State Building Orders.

Details concerning the fire resistance classes according to DIN 4102 are shown in italics as a “comparison”. The varying test and assessment procedures applied to fire resistance classes according

to German and European standards mean that a complete comparability is not possible; hence the values are intended merely to provide guidance.

In summary, although the European classification and test standards on the fire behaviour of components/ construction types can be used to test and classify on a European level, and although they exist as equals to the German DIN 4102 standard, fitness for purpose remains controlled by national regulations. It is therefore of the utmost importance to define and describe all requirements unequivocally during the phase of coexistence.

Table 4: Fire resistance classes of selected components according to DIN EN 13501 Part 2 and Part 3

Building inspectorate requirements	Supporting components		Non-supporting interior walls	Non-supporting exterior walls	Self-supporting suspended ceilings	Fire barriers (also in transport systems)
	without protective barrier	with protective barrier				
Fire-retardant	R 30	REI 30	EI 30	E 30 (i → o) EI 30 (i ← o)	E 30 (a → b) EI 30 (a ↔ b) EI 30 (a ↔ b)	EI2 30-C
	<i>F 30</i>	<i>F 30</i>	<i>F 30</i>	<i>W 30</i>	<i>F 30</i>	<i>T 30</i>
highly fire-retardant	R 60	REI 60	EI 60	E 60 (i → o) EI 60 (i ← o)	E 60 (a → b) EI 60 (a ↔ b) EI 60 (a ↔ b)	EI2 60-C
	<i>F 60</i>	<i>F 60</i>	<i>F 60</i>	<i>W 60</i>	<i>F 60</i>	<i>T 60</i>
not easily flammable	R 90	REI 90	EI 90	E 90 (i → o) EI 90 (i ← o)	E 90 (a → b) EI 90 (a ↔ b) EI 90 (a ↔ b)	EI2 90-C
	<i>F 90</i>	<i>F 90</i>	<i>F 90</i>	<i>W 90</i>	<i>F 90</i>	<i>T 90</i>
Fire resistance after 120 min	R 120 <i>F 120</i>	REI 120 <i>F 120</i>				
Fire wall		REI 90-M <i>F 90</i>	EI 90-M <i>F 90</i>			

Column 1 shows the assignment to the building inspectorate requirements

Content shown in italics indicates the comparable fire resistance classes according to DIN 4102

Construction law / Standardisation

9.7
2

Product-specific classifications and terms

The following section provides a more precise definition of some terms, as the standards regulate a large number of construction materials/products, i.e. components/building types and at the same time influence construction law regulations.

Fire-resistant glazing

Fire-resistant glazings are components comprising one or several translucent elements, installed in a frame with holder and enclosed within sealing and fastening elements prescribed by the manufacturer. The product can only be considered fire-resistant glazing if it consists of the entirety of these constructive elements and complies with all prescribed dimensions and dimensional tolerances.

Fire-resistant glazing in fire resistance class F (F glazing)

The term F glazing applies to all translucent building components in a vertical, inclined or horizontal alignment that are designed not merely to prevent the spread of fire and smoke as designated in their fire resistance duration, but also to stop transmittance of heat radiation.

Fire resistance glazing in fire resistance class G (G glazing)

The term F glazing applies to all translucent building components in a vertical, inclined or horizontal alignment that are designed merely to prevent the spread of fire and smoke as designated in their fire resistance duration. Transmittance of heat radiation is merely impeded.

Fire-retardant glazing

Fire-retardant glazing is the name give to fire-resistant glazing that satisfies at least the requirements of F 30. It stipulates that fire-retardant glazing shall be F glazing that is impervious to heat radiation for a period of at least 30 minutes in accordance with the requirements of DIN 4102 Part 13.

Fireproof glazing

Fireproof is the name give to fire-resistant glazing that satisfies at least the requirements of F 90. It stipulates that fire-retardant glazing shall be F glazing that is impervious to heat radiation for a period of at least 90 minutes

in accordance with the requirements of DIN 4102 Part 13.

“Fire resistance” glazing

Glazing described as fire-resistant provides a room barrier according to DIN 4102 Part 13 in the case of fire, but it permits the transmittance of heat and hence is not used with the building inspectorate designations or “fire-retardant” and “fireproof”. This includes all G glazing

Fire resistance classes according to DIN 4102

Fire resistance duration in minutes	F glazing	G glazing
≥ 30	F 30	G 30
≥ 60	F 60	G 60
≥ 90	F 90	G 90
≥ 120	F 120	G 120

The following terms and classifications are equivalent to the European provisions: The letters R, E, I and W are used to describe the fire resistance capability. S and C describe criteria applicable to fire doors and fire barriers.

R (Resistance / Loadbearing capacity)

The capability of a component to withstand fire stress from one or several sides without losing stability.

E (Étanchéité / Room barrier)

The capability of a component to act as a barrier to a room and to withstand fire stress from one side. It prevents the spread of fire to the side away from the fire caused by the passage of flames or substantial quantities of hot gases that would lead to combustion on the side away from the fire or in adjacent material.

W (Radiation / Radiation reduction)

The capability of a component to act as a barrier to a room and to withstand fire stress from one side such that the heat radiation measured on the side away from the fire remains below a certain value for a defined period.

Construction law / Standardisation

9.7
2

I (Isolation)

The capability of a construction component to withstand fire load applied from just one side without transferring the fire due to an excessive transmittance of heat from the fire side to the side opposite the fire, thus leading to combustion in the side opposite the fire or of adjacent materials, as well as the capability to present a sufficiently strong thermal barrier for the period defined in the classification in order to protect the lives of persons located in the vicinity of the structural element.

S (Smoke)

The capability of a construction component to restrict the movement of hot or cold gases or smoke from one side to the other.

C (Closing)

The capability of a construction component to automatically close an opening (either after each opening or only in cases of fire) in the event of the emergence of fire or smoke.

Classification of the fire resistance of non-loadbearing fire resistant glazing enclosing a space

a) Curtain walls and exterior walls (EN 1364-2, EN 1364-4)

Fire resistance duration in minutes	E glazing	EW glazing	EI glazing
15	E-15		EI-15
20		EW-20	EI-20
30	E-30	EW-30	EI-30
45	E-45		EI-45
60	E-60	EW-60	EI-60
90	E-90		EI-90

Curtain walls and exterior walls can be tested in different ways from both sides:

- Fire exposure from inside:
Uniform temperature curve
- Fire exposure from outside:
A temperature/time curve equivalent to ETK to 600°C and then even for the rest of the test duration.

The following abbreviation describes the direction of the classified fire resistance duration

“i → o” / inside - outside

“o → i” / outside - inside

“i → o” / inside and outside

The classification of curtain facades and exterior walls usually refers to both loads.

b) Partition walls (EN 1364-1)

Fire resistance duration in minutes	E glazing	EW glazing	EI glazing
15			EI-15
20	E-20	EW-20	EI-20
30	E-30	EW-30	EI-30
45			EI-45
60	E-60	EW-60	EI-60
90	E-90		EI-90
120	E-120		EI-120
180			EI-180
240			EI-240

c) Fire barriers (EN 1634-1)

Fire resistance duration in minutes	E glazing	EW glazing	EI glazing
15	E-15		EI-15
20		EW-20	EI-20
30	E-30	EW-30	EI-30
45	E-45		EI-45
60	E-60	EW-60	EI-60
90	E-90		EI-90
120	E-120		EI-120
180	E-180		EI-180
240	E-240		EI-240

Classifications C and S may be necessary in addition for certain types of fire barrier.

Construction law / Standardisation

9.7
2

Validation process

Allocation of the DIN classifications within the Federal State Building Order

The terms used by the building inspectorate of “fire retardant” and “fire resistant” are not mentioned in DIN 4102. The federal states of Germany issued decrees to introduce DIN 4102 within building inspectorate procedures that specify whether components classified in fire resistance classes according to this standard should be considered “fire retardant” or “fire resistant”.

Official validation of fitness for purpose

The suitability of construction materials or components for the purpose of fire resistance in structural engineering must usually be provided in the form of a test certificate issued by an accredited test institute.

This does not apply to construction materials and components that are listed and classified in DIN 4102 Part 4. Components that cannot be assessed solely according to DIN 4102 require separate validation. Fire resistance glazing belongs in this category.

General construction test certificate (abP)

A general construction test certificate (abP) is a proof of fitness for purpose that is issued for a construction product whose use is not associated with the satisfaction of significant requirements in regard to the safety of structures, or for a construction product that can be assessed according to generally accepted test methodologies (Sect 19 (1) Model Building Code (MBO)). The Construction Product List A Part 1, Part 2 and Part 3 state in detail for which products an abP can be issued. Exclusively the test institutes accredited by the Deutsche Institut für Bautechnik (DIBt) or the most senior building inspectorate are entitled to issue an abP.

An abP cannot be issued for fire-resistant glazing.

General building authorisation (abZ)

General building authorisations (abZ) are issued for construction products and construction techniques that are governed by the Federal State Building Codes and for which there are no generally acknowledged rules of technology, in particular DIN standards, or that differ substantially from these rules. Exclusively the Deutsche Institut für Bautechnik issues general building authorisations on behalf of the federal states. They are a validation of the

fitness for purpose, i.e. suitability for use, of an unregulated construction product or an unregulated construction technique in regard to the building inspectorate requirements defined in the Federal State Building Codes. Fire-resistance glazing is regulated by abZs.

Case-by-case approval

Case-by-case approval, known as ZiE, can be applied for if fire-resistance glazing approved by the building inspectorate is not available to satisfy a certain requirement. This applies also if the actual construction implemented differs from the approval. The case-by-case approval replaces the missing approval by the building inspectorate in an exceptional instance.

The principal must place an application for this approval with the senior building inspectorate in the respective federal state in which the project is being implemented. In most cases an application for case-by-case approval will be granted if test findings validate the fitness for purpose or if there are equivalent findings available elsewhere (assessor’s report), or if the effort involved in performing the tests is considered unreasonable and if the use in the intended construction technique is considered acceptance from a fire-resistance perspective.

The following page lists the competent bodies in the individual federal states.

Assessor’s report

An assessor’s report (GaS) if issued by a state-accredited test institute. It is considered a validation of fitness for purpose in place of testing, provided this can be ascertained by an expert’s opinion. It is submitted to the Deutsche Institut für Bautechnik, i.e. to the competent senior building inspectorate. The application for an assessor’s report should always take place in consultation with the senior building inspectorate. It is advisable to commission the report from the test institute that performed the fire tests for the respective approval.

These are the following institutes for the approval of Norden Facade systems:

Construction law / Standardisation

9.7
2

Test body	Telephone	Telefax
MPA NRW Materialprüfamt Nordrhein-Westfalen Erwitte Branch, Auf den Thränen 2 D-59597 Erwitte	+49 (0)2943/8970 (Switchboard) +49 (0)2943/89715 (Mr Werner)	+49 (0)2943/89733
IBMB MPA Braunschweig Materialprüfamt für das Bauwesen Beethovenstraße 52 D-38106 Braunschweig	+49 (0)531/391/5472 (Switchboard) +49 (0)531/391 5909	+49 (0)531/391 8159

Competent authorities for the issue of approval in individual cases

Federal state	Ministry	Telephone	Telefax
Baden-Württemberg	Haus der Wirtschaft, Landesstelle für Bautechnik, Willy Bleicher Straße 19, D-70174 Stuttgart	+49 (0)711 /1230 (Switchboard) +49 (0)711 /123 3385	+49 (0)711 /123 3388
Free State of Bavaria	Bayerisches Staatsministerium des Innern, -Oberste Baubehörde- Postfach 22 00 36, D-80535 Munich	+49 (0)89 /219202 (Switchboard) +49 (0)89 /2192 3449 (Dr Schu- bert) 089 /2192 /3496 (Hr. Keil)	+49 (0)89 /2192 13498
Berlin	Senatsverwaltung für Stadtentwicklung -II- Prüfamt für Bautechnik und Rechtsangelegenheiten der Bauaufsicht, Abteilung 6E21 Württembergische Straße 6, D-10702 Berlin	+49 (0)30 /900 (Switchboard) +49 (0)30 /90124809 (Dr Espich)	+49 (0)30 /901 23 525
Brandenburg	Ministerium für Stadtentwicklung, Wohnen und Verkehr des Landes Brandenburg, Referat 24 Henning-von-Tresckow-Straße 2-8 D-14467 Potsdam	+49 (0)331 /8660 (Switchboard) +49 (0)331 /866 8333	+49 (0)331 /866 8363
Free Hanseatic City of Bremen	Free Hanseatic City of Bremen Der Senator für Bau und Umwelt Ansgaritorstraße 2, D-28195 Bremen	+49 (0)421 /3610 (Switchboard)	
Free Hanseatic City of Hamburg	Free Hanseatic City of Hamburg Amt für Bauordnung und Hochbau Stadthausbrücke 8, D-20355 Hamburg	+49 (0)40 /428400 (Switchboard) +49 (0)40 /428 40 3832	+49 (0)40 /428 40 3098
Hesse	Hessisches Ministerium für Wirtschaft, Verkehr und Landesentwicklung -Abteilung VII- Kaiser-Friedrich-Ring 75, D-65185 Wiesbaden	+49 (0)611 /8150 (Switchboard) +49 (0)611 /815 2941	+49 (0)611 /815 2219
Mecklenburg-Vorpom- mern	Ministerium für Arbeit und Bau Mecklenburg- Vorpommern Abteilung II, Schloßstraße 6-8 D-19053 Schwerin	+49 (0)385 /5880 (Switchboard) +49 (0)385 /588 3611 (Mr Harder)	+49 (0)385 /588 3625
Lower Saxony	Niedersächsisches Innenministerium, Abteilung 5 Lavesallee 6, D-30169 Hannover	+49 (0)511 /1200 (Switchboard) +49 (0)511 /120 2924 (Mr Bode) +49 (0)511 /120 2925 (Mr Janke)	+49 (0)511 /120 3093
North Rhine Westphalia	Ministerium für Städtebau und Wohnen, Kultur und Sport des Landes Nordrhein-Westfalen, Abteilung II, Elisabethstraße 5-11 D-40217 Düsseldorf	+49 (0)211 /38430 (Switchboard) +49 (0)211 /384 3222	+49 (0)211 /384 3639
Rhineland Palatinate	Ministerium für Innen und Sport des Landes Rhein- land-Pfalz Schillerstraße 3-5, D-55116 Mainz	+49 (0)6131 /160 (Switchboard) +49 (0)6131 /163406	+49 (0)6131 /163447
Saarland	Ministerium für Umwelt, Oberste Bauaufsicht Keppelerstraße 18, D-66117 Saarbrücken	+49 (0)681 /50100 (Switchboard) +49 (0)681 /501 4771 (Ms Elleger)	+49 (0)681 /501 4101
Saxony Anhalt	Ministerium für Wohnungswesen, Städtebau und Verkehr des Landes Sachsen-Anhalt, Abteilung II Turmschanzenstraße 30, D-39114 Magdeburg	+49 (0)391 /56701 (Switchboard) +49 (0)391 /567 7421	

Construction law / Standardisation

9.7
2

Federal state	Ministry	Telephone	Telefax
Free State of Saxony	Sächsisches Staatsministerium des Innern, Abteilung 5, Referat 53 Wilhelm-Buck-Straße 2, D-01095 Dresden	+49 (0)351 / 5640 (Switchboard) +49 (0)351 / 643530 (Dr Fischer)	+49 (0)351 / 5643509
Schleswig-Holstein	Innenministerium des Landes Schleswig-Holstein, Bauaufsicht und Landesbauordnung, Referat IV 65 Düsternbrooker Weg 92, D-24105 Kiel	+49 (0)431 / 9880 (Switchboard) +49 (0)431 / 9883319 (Mr Dammann)	+49 (0)431 / 9882833
Thuringia	Oberste Bauaufsichtsbehörde im Thüringer Innen- ministerium Referat 50b, Bautechnik, Steigerstraße 24, D-99096 Erfurt	+49 (0)361 / 37900 (Switchboard) +49 (0)361 / 3793931 (Ms Müller)	+49 (0)361 / 3793048

Burglary-resistant facades

9.8
1

Recommendations for use

The selection of applicable resistance class must be made to reflect the individual hazard exposure, for instance the location of the property or the exposure of the particular element. The police services information centres and insurance providers offer assistance in this respect.

DIN EN 1627 assigns construction components to the resistance classes RC1 to RC6. They each define minimum requirements for the system and the mounted glazing and panels.

Regulations and testing

The standard DIN EN1627 defines the requirements for and classification of a burglary-resistant facade. The test methods used to determine resistance under static and dynamic load are defined in the standards DIN EN 1628 and DIN EN 1629. The test method for the determination of resistance to manual burglary attempts is defined in DIN EN 1630. Validation of adherence to the requirements set forth in the aforementioned standards must be obtained from an accredited test institute. The filling elements used are governed by the standard DIN EN 356.

Labelling and validation obligations

The system provider must submit assembly instructions and a test report as minimum requirements. An assessor's report clarifies the influence of deviations in or changes to the test specimens in respect of their capability to withstand burglary attempts.

An assembly certificate should be obtained from the facade manufacturer, confirming that assembly was performed professionally and according to the assembly instructions issued by the system provider. DIN EN 1627 contains a template for this purpose. Norden Facade can also provide a suitable template. The assembly certificate must be submitted to the principal.

The processor can also, as a means of voluntary quality assurance, obtain certification according to DIN CERTCO or an alternative certification institute accredited according to DIN EN 45011.

In this case, construction components with burglary-resistant properties must be labelled permanently, for instance using a name plate attached discretely on the facade. The name plate must be clearly legible and have a minimum size of 105 mm x 18mm; it must contain the following information at least:

- Burglary-resistant component according to DIN EN 1627
- Achieved resistance class
- Product designation by the system provider
- Certification mark if applicable
- Manufacturer
- Test report number ..., date ...
- Notifying body, code as applicable
- Year of manufacture

Police services only recommend the use of a business certified by an accredited certification institute. The certification programme "Burglary protection", which is available from DIN CERTCO, contains additional information on the issue of the "DIN tested" label.

Tested systems

- Norden RC 2
Facade H RC 2
- Norden
Facade AK-H

Burglary-resistant facades

9.8
1

Design

The most important properties in the construction of a burglary-resistant facade are:

- Use of tested panes and panels as filling elements.
- Definition of the inlay depth for the filling elements.
- Installation of lateral blocks to prevent displacement of the filling elements.
- Use of a stainless steel bottom strip for the clamp connection.
- Definition of the screw spacing and the screw depths
- Securing of the screws against loosening.

The appearance of burglar-resistant facades using Norden Facade System H is the same as the normal construction.

- The same design options and styles are possible as with a normal construction.
- All upper strips can be used when fitting stainless steel bottom strips.
- All inner seal systems (1, 2 and 3 sections) can be used.
- Norden Facade system H preserves all of the benefits thanks to direct screw fittings in the milled groove.

Burglary-resistant facades - RC2

9.8
2

Resistance class RC2

In Norden Facade H, facades in resistance class RC2 can be mounted in the system widths 50 mm, 60 mm and 80 mm.

Compared to a normal facade, this only requires a minor additional manufacturing workload in order to achieve resistance class RC2.

- Securing of the filling elements against lateral displacement.
- Arrangement and selection of the clamping strip screw fittings relative to the permissible axis dimensions in the fields.
- Securing of the clamping strip screw fitting against loosening.

System articles and filling elements are only approved for use if they have been tested and received a positive assessment.

It is always necessary to validate that in the dimensions selected, the components used will satisfy the static requirements placed in the system for the specific project.

The design options for the facade remain preserved, as all aluminium upper strips that can be clipped on to the stainless steel bottom strips UL 5110, UL 6110 and UL 8110 can still be used.

Sealing systems

The inner sealing system for burglary-resistant facades can also use systems with 1 section or overlapping sealing systems with 2 or 3 sections.

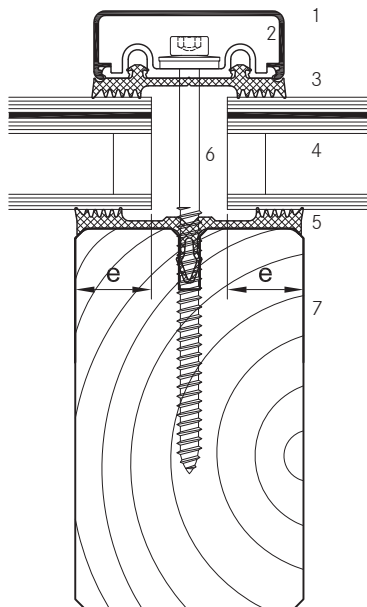

Inset "e" of the filling element
System width 50 mm: s= 15 mm
System width 60 mm: e = 20 mm
System width 80 mm: e = 20 mm

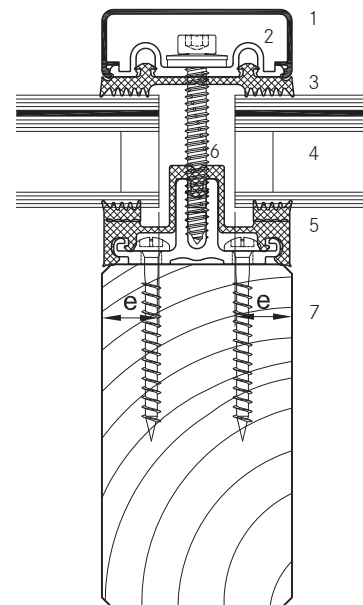

TI-H_9.8_001.dwg

- 1 Upper strip
- 2 Bottom strip
- 3 Outer seal
- 4 Filling element
- 5 Inner seal
(e.g. with 1 drainage level)
- 6 System screw fittings
- 7 Timber support profile

Burglary-resistant facades - RC2

9.8
2

Approved system articles for the Norden Facade H system

System components Norden Facade H	System width 50 mm	System width 60 mm	System width 80 mm ¹⁾
Mullion cross-section minimum dimensions	Timber profile, width b = 50 mm height at least H = 70 mm	Timber profile, width b = 60 mm height at least H = 70 mm	Timber profile, width b = 80 mm height at least H = 70 mm
Transom cross-section minimum dimensions	Timber profile, width b = 50 mm height at least H = 70 mm	Timber profile, width b = 60 mm height at least H = 70 mm	Timber profile, width b = 80 mm height at least H = 70 mm
Mullion-transom joint	bolted transom retainer ac- cording to the general building authorisation, or timber connec- tion validated by the standard	bolted transom retainer ac- cording to the general building authorisation, or timber connec- tion validated by the standard	bolted transom retainer ac- cording to the general building authorisation, or timber connec- tion validated by the standard
	e.g. GD 5201	e.g. GD 6202	e.g. GD 8202
Inner seal mullions		e.g. GD 6206	
	e.g. GD 5314	e.g. GD 6314	e.g. GD 8314
	e.g. GD 5315	e.g. GD 6315	e.g. GD 8315
Inner seal transom (with connected transom)	e.g. GD 5203, GD 5204	e.g. GD 6204, e.g. GD 6205	e.g. GD 8204
		e.g. GD 6303	
	e.g. GD 5317	e.g. GD 6318	e.g. GD 8318
Outer seal mullion	e.g. GD 5024, GD 1932	e.g. GD 6024, GD 1932	e.g. GD 8024, GD 1932
Outer seal transom	e.g. GD 5054, GD 1932	e.g. GD 6054, GD 1932	e.g. GD 1932
Clamping strips	UL 5009	UL 6009	UL 8009
Screw fittings for clamping strips	System screws (cylinder head screw with sealing washer, internal hex, stainless steel, e.g. Z 0335)	System screws (cylinder head screw with sealing washer, internal hex, stainless steel, e.g. Z 0335)	System screws (cylinder head screw with sealing washer, internal hex, stainless steel, e.g. Z 0335)
Glass supports	GH 5053, i.e. GH 5055 (with hanger bolts, i.e. hardwood cylinders and bolts)	GH 5053, i.e. GH 5055 (with hanger bolts, i.e. hardwood cylinders and bolts)	GH 5053, i.e. GH 5055 (with hanger bolts, i.e. hardwood cylinders and bolts)
Lateral blocks	e.g. Z 1061 or blocks b x h = 24 mm x 20 mm Length l = 120 mm, cut from PUR recycling material (e.g. Purenit, Phonotherm)	e.g. Z 1061 or blocks b x h = 24 mm x 20 mm Length l = 120 mm, Cut from PUR recycling material (e.g. Purenit, Phonotherm)	Blocks b x h = 36 mm x 20 mm Length l = 120 mm, cut from PUR recycling material (e.g. Purenit, Phonotherm)
Screw locks	not necessary	not necessary	not necessary

1) System articles for the system width 80 mm available only on request

Burglary-resistant facades - RC2

9.8
2

Approved system articles for the Norden Facade AK-H system

System components Norden Facade AK-H	System width 50 mm	System width 60 mm	System width 80 mm ¹⁾
Mullion cross-section minimum dimensions	Timber profile, width b = 50 mm height at least H = 70 mm	Timber profile, width b = 60 mm height at least H = 70 mm	Timber profile, width b = 80 mm height at least H = 70 mm
Transom cross-section minimum dimensions	Timber profile, width b = 50 mm height at least H = 70 mm	Timber profile, width b = 60 mm height at least H = 70 mm	Timber profile, width b = 80 mm height at least H = 70 mm
Mullion-transom joint	bolted transom retainer ac- cording to the general building authorisation, or timber connec- tion validated by the standard	bolted transom retainer ac- cording to the general building authorisation, or timber connec- tion validated by the standard	bolted transom retainer ac- cording to the general building authorisation, or timber connec- tion validated by the standard
Inner seal mullions	GD 5071	GD 6071	GD 8071
Inner seal transom (with connected transom)	GD 5072	GD 6072	GD 8072
	GD 5073	GD 6073	GD 8073
Outer seal mullion	e.g. GD 5024, GD 1932	e.g. GD 6024, GD 1932	e.g. GD 8024, GD 1932
Outer seal transom	e.g. GD 5054, GD 1932	e.g. GD 6054, GD 1932	e.g. GD 1932
Clamping strips	UL 5009	UL 6009	UL 8009
Screw fittings for clamping strips	System screws (cylinder head screw with sealing washer, internal hex, stainless steel, e.g. Z 0335)	System screws (cylinder head screw with sealing washer, internal hex, stainless steel, e.g. Z 0335)	System screws (cylinder head screw with sealing washer, internal hex, stainless steel, e.g. Z 0335)
Glass supports	GH 6071, GH 6072	GH 6071, GH 6072	GH 6071, GH 6072
Lateral blocks	e.g. Z 1061 or blocks b x h = 24 mm x 20 mm Length l = 120 mm, cut from PUR recycling material (e.g. Purenit, Phonotherm)	e.g. Z 1061 or blocks b x h = 24 mm x 20 mm Length l = 120 mm, Cut from PUR recycling material (e.g. Purenit, Phonotherm)	Blocks b x h = 36 mm x 20 mm Length l = 120 mm, cut from PUR recycling material (e.g. Purenit, Phonotherm)
Screw locks	not necessary	not necessary	not necessary

1) System articles for the system width 80 mm available only on request

Burglary-resistant facades - RC2

9.8
2

Filling elements

It is important to check on-site that the filling elements satisfy the static requirements of the project.

Glazing and panels must satisfy the requirements of at least DIN EN 356.

Glass

To satisfy resistance class RC2, it is necessary to fit impact-resistant glazing type P4A, as provided by the firm SAINT GOBAIN. The total structure of the glass has a thickness of approx. 30 mm.

- Product SGG STADIP PROTECT CP 410
- Resistance class P4A
- Multi-pane insulating glass, glass structure from outside in.
- 4 mm float / 16mm SZR / 9.52 mm VSG
- Glass thickness $\Delta = 29,52 \text{ mm} \approx 30 \text{ mm}$
- Glass weight approx. 32 kg/m^2

Panel

Panel structure:

3 mm aluminium sheet / 24 mm PUR (or comparable material) with reinforced edge bonding / 3 mm aluminium sheet. The total thickness is 30 mm.

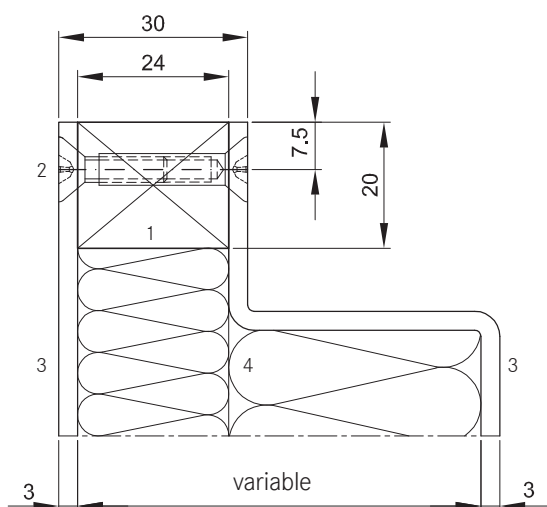

Edge bonding:

A circumferential edge of 24mm x 20 mm made of PUR recycling material (e.g. Purenit, Phonotherm) is inserted to reinforce the panels. Both sheets are screwed together in the area of the edge bonding; screws are positioned on each side in intervals of $a \leq 116 \text{ mm}$ and screwed together along the entire length. Stainless steel screws $\varnothing 3.9 \text{ mm} \times 38 \text{ mm}$ can be used in this respect; they are cut off and ground down on the side not exposed to an attack. Fixing screws / nuts M4 can be used alternatively.

It is permitted, in order to satisfy additional requirements placed in the panel (e.g. in regard to thermal insulation), to deviate from the cross-section geometry shown in the diagram below. This applies only if the material thickness of the sheet aluminium $t = 3 \text{ mm}$ is preserved and the edge bonding is prepared as described above.

Inset of the filling elements

The inset of the filling elements is $e = 15 \text{ mm}$ for timber profiles in the system width 50 mm. The inset of the filling elements is $e = 20 \text{ mm}$ for timber profiles in the system width 60 mm and 80 mm.

- 1 Edge bonding
- 2 Screw fittings, e.g. fixing screw / nut M4
- 3 Aluminium sheet $t = 3 \text{ mm}$
- 4 Insulation

TI-H_9.8_002.dwg

Burglary-resistant facades - RC2

9.8
2

Lateral blocks on the filling elements

The filling elements must be secured against lateral displacement. Installation of a lateral, pressure-resistant blocks prevents any displacement of the filling elements in the event of manipulation.

One block must be fitted in each corner of the mullion rebate. The blocks must be glued into the system. The glue used must be compatible with the edge bonding of the filling elements and the blocks. The blocks

can also be fixed in place by screwing them to the timber profile.

In addition to the blocks used in the test (art. no. Z 1061, plastic tube h x b x t = 20 mm x 24 mm x 1.0 mm, length $l = 120$ mm), the blocks can also be cut out of another pressure-resistant, non-absorbent material such as PUR recycling material (e.g. Purenit, Photherm).

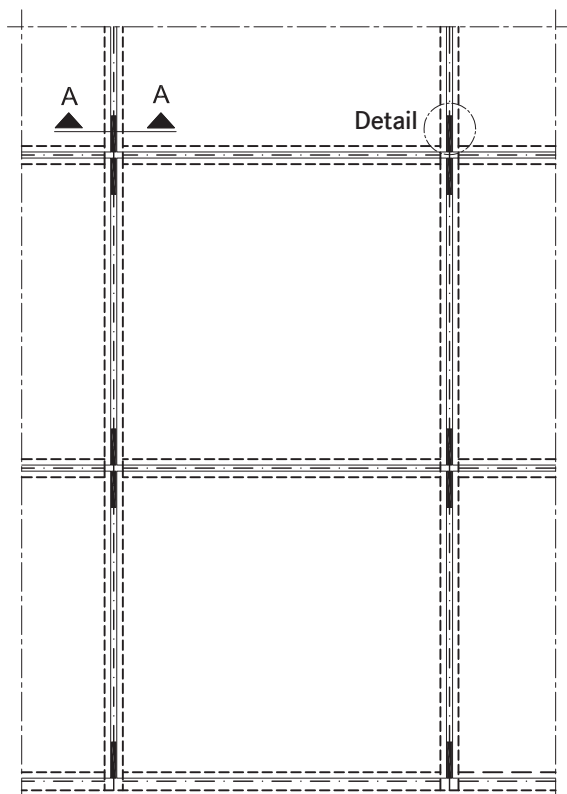

Cut A - A

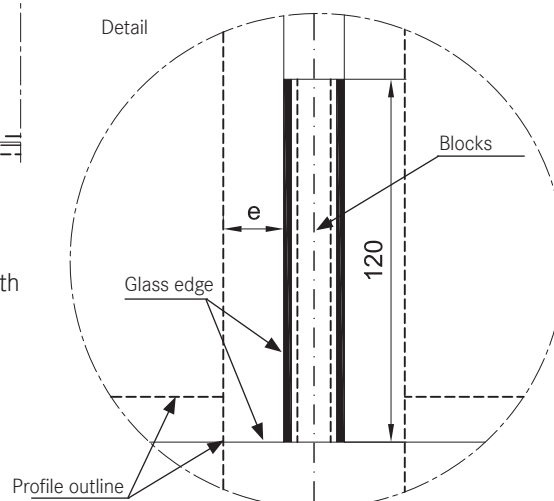
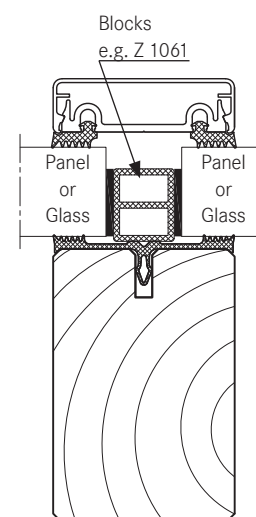

*)Glue in the blocks (the glue must be compatible with the edge bonding of the filling elements)
or
Use fixing screw to secure the position in the central groove

TI-H_9.8_003.dwg

Burglary-resistant facades - RC2

9.8
2

Screw fittings for clamping strips System H

- The screw fitting is positioned in the central groove of the timber profiles.
- The screw length must be calculated for each project.
- The effective insertion depth of the screws is $l_{ef} \geq 41$ mm.
- Holes must be pre-drilled with $0.7 \cdot d = 4.6$ mm to hold the screw fittings.
- The edge distance of the screw fittings for clamping strips is defined as $a_R = 30$ mm.
- The selection and arrangement of the screw fittings depends on the axis dimensions of the fields. The maximum distance between screws is $a = 125$ mm and must on no accounts be exceeded.
- The axis dimensions B and H can be selected indefinitely, the minimum field size is 485 x 535 mm. There must be at least 5 screws per side.

Securing clamping strip screw fittings against loosening

Securing the clamping strip screw connection is not necessary with the Norden Facade H system.

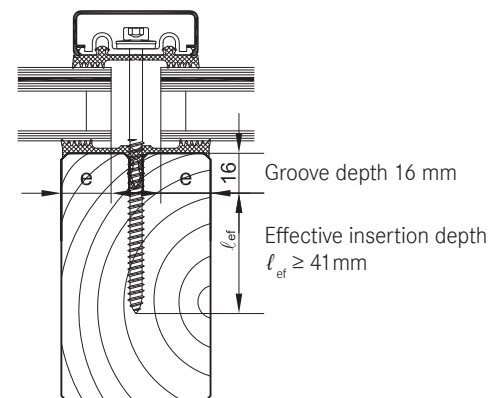
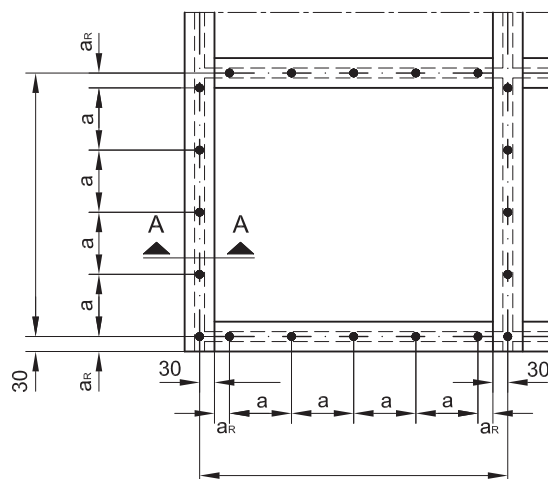

Burglary-resistant facades - RC2

9.8
2

Screw fittings for clamping strips System AK-H

- The screw fitting is positioned in the screw channel.
- The screw length must be calculated for each project.
- The edge distance of the screw fittings for clamping strips is defined as $a_r = 30$ mm.
- The selection and arrangement of the screw fittings depends on the axis dimensions of the fields. The maximum distance between screws is $a = 125$ mm and must on no accounts be exceeded.
- The axis dimensions B and H can be selected indefinitely, the minimum field size is 485 x 535 mm. There must be at least 5 screws per side.

Securing clamping strip screw fittings against loosening

Securing the clamping strip screw connection is not necessary with the Norden Facade AK-H system.

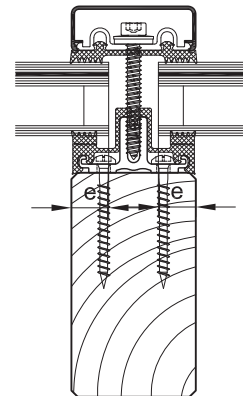
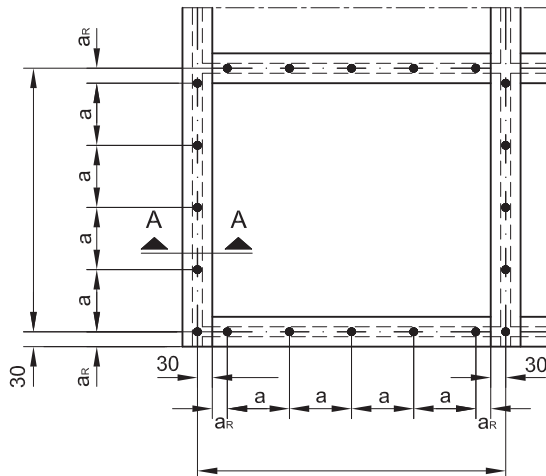

Burglary-resistant facades - RC2

9.8
2

Assembly instructions Norden Facade H

The processing instructions provided in Section 1.2 of the catalogue apply as a rule to the system Norden Facade H. The following items must be considered additionally and executed in the necessary stages of processing in order to satisfy the criteria of resistance class RC2.

- 1 Construction of the facade using the tested system articles and according to static requirements.
- 2
- 3
- 4
- 5
- 6 The glass supports should be positioned so that they can be mounted between the 125 mm screw grid.
- 7 The support of the mullions (head, foot and intermediate support) must be calculated with sufficient static leeway so that any forces applied during an attempted burglary can be absorbed with certainty. Accessible fixing screws must be secured against unauthorised loosening.
- 8 Burglary-resistant components are intended for installation in solid walls. The minimum requirements provided in DIN EN 1627 apply to wall connections.

The filling elements (glass and panel) must be impact-resistant according to DIN EN 356. Tested glazing of the type P4A, for instance by SGG STADIP PRO-TECT CP 410 with approx. 30 mm glass structure, must be used in order to obtain resistance class RC2. The panel structure must be the same as the tested panel structure.

- 4 The inset of the filling elements is $e = 15$ mm for timber profiles in the system width 50 mm. The inset of the filling elements is $e = 20$ mm for timber profiles in the system width 60 mm and 80 mm.

- 5 Blocks must be used to secure the filling elements against lateral displacement. To achieve this, blocks are needed in each filling corner in the rebate of the mullion.

Exclusively Norden Facade system screws with sealing washers and internal hex may be used (e.g. article no. Z 0335). The effective insertion depth of the screws, measured below the central groove, must be $l_{ef} \geq 41$ mm. The edge distance of the screw fittings for clamping strips is $a_R = 30$ mm.

The maximum bolt spacing between them must not exceed

Assignment of burglary-resistant components in resistance class RC2 to the walls

Resistance class of the burglary-resistant component according to DIN EN 1627	Surrounding walls							
	Masonry according to DIN 1053 - 1			Reinforced concrete according to DIN 1045		Aerated concrete wall		
	Rated thickness	Compressive strength class of the blocks	Mortar group	Rated thickness	Strength class	Rated thickness	Compressive strength class of the blocks	Execution
RC2	≥ 115 mm	≥ 12	II	≥ 100 mm	$\geq B 15$	≥ 170 mm	≥ 4	glued

Burglary-resistant facades - RC2

9.8
2

Assembly instructions Norden Facade AK-H

The processing instructions provided in Section 3.2 of the catalogue apply as a rule to the system Norden Facade AK-H. The following items must be considered additionally and executed in the necessary stages of processing in order to satisfy the criteria of resistance class RC2.

- 1 Construction of the facade using the tested system articles and according to static requirements.

The filling elements (glass and panel) must be impact-resistant according to DIN EN 356. Tested glazing of the type P4A, for instance by SGG STADIP PRO-TECT CP 410 with approx. 30 mm glass structure, must be used in order to obtain resistance class RC2. The panel structure must be the same as the tested panel structure.

3

The inset of the filling elements is $e = 15$ mm for timber profiles in the system width 50 mm. The inset of the filling elements is $e = 20$ mm for timber profiles in the system width 60 mm and 80 mm.

4

Blocks must be used to secure the filling elements against lateral displacement. To achieve this, blocks are needed in each filling corner in the rebate of the mullion.

5

Exclusively Norden Facade system screws with sealing washers and internal hex may be used (e.g. article no. Z 0156). The edge distance of the screw fittings for clamping strips is $a_r = 30$ mm.

The maximum bolt spacing between them must not exceed the value $a = 125$ mm.

- 6 The glass supports should be positioned so that they can be mounted between the 125 mm screw grid.

- 7 The support of the mullions (head, foot and intermediate support) must be calculated with sufficient static leeway so that any forces applied during an attempted burglary can be absorbed with certainty. Accessible fixing screws must be secured against unauthorised loosening.

- 8 Burglary-resistant components are intended for installation in solid walls. The minimum requirements provided in DIN EN 1627 apply to wall connections.

Assignment of burglar-resistant components in resistance class RC2 to the walls

Resistance class of the burglary-resistant component according to DIN EN 1627	Surrounding walls							
	Masonry according to DIN 1053 - 1			Reinforced concrete according to DIN 1045		Aerated concrete wall		
	Rated thickness	Compressive strength class of the blocks	Mortar group	Rated thickness	Strength class	Rated thickness	Compressive strength class of the blocks	Execution
RC2	≥ 115 mm	≥ 12	II	≥ 100 mm	$\geq B 15$	≥ 170 mm	≥ 4	glued