

Norden Facade SOL



4.1	Norden Facade SOL - System	3
4.1.1	System properties	3
4.1.2	System design	7
4.1.3	Attachment to the building	8
4.1.4	Determining the lamellae spacing	9
4.1.5	Lamella forms and lamella spacing	10
4.1.6	Cleaning function	11
4.2	Norden Facade SOL - Project planning	13
4.2.1	Project planning with Norden Facade SOL	13

By EFTCG

NODDEN
F A C A D E
NODDEN

System properties

4.1
1

Sun protection system

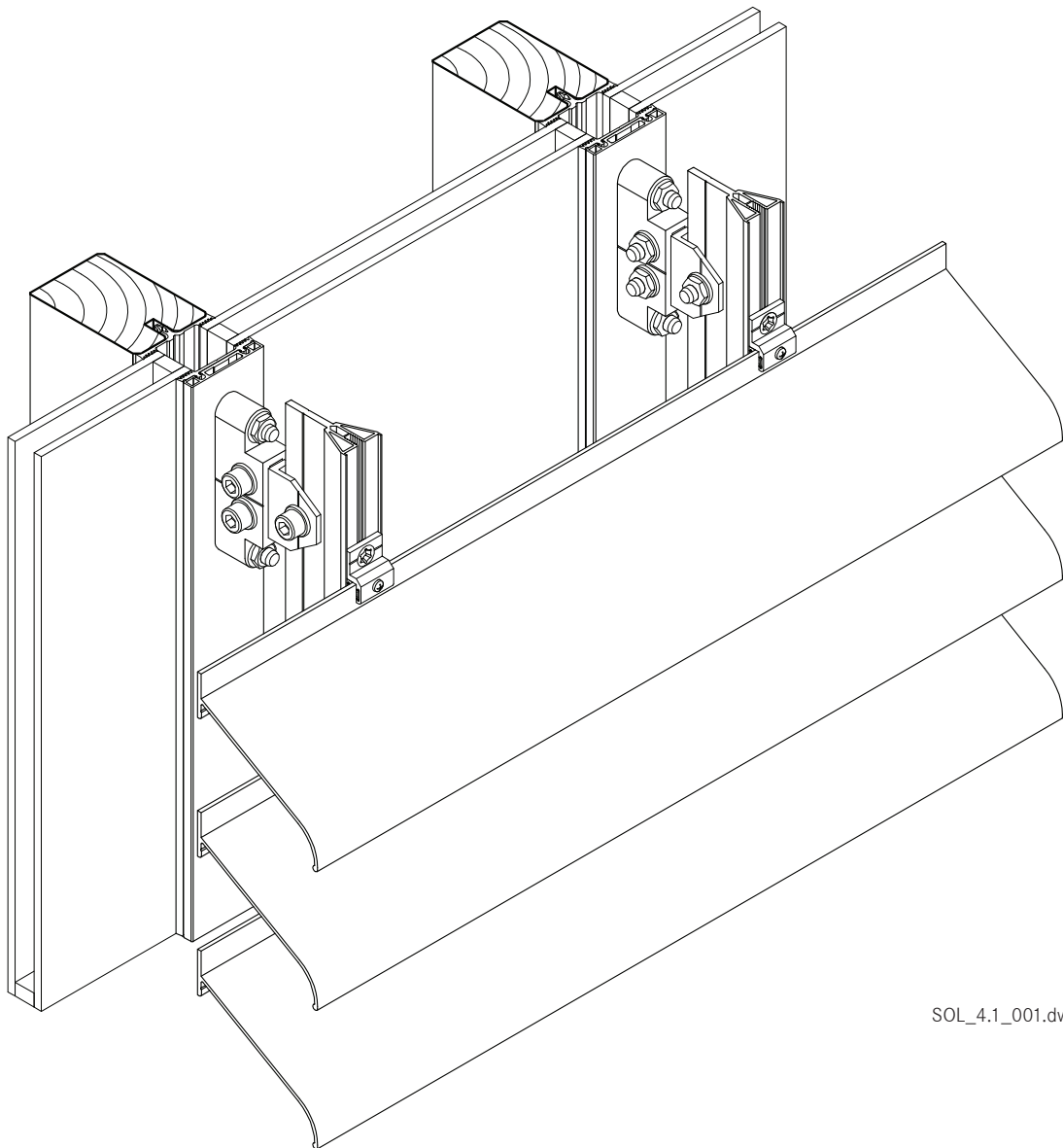

SOL_4.1_001.dwg

System properties

4.1
1

Norden Facade SOL system description

Norden Facade SOL is a rigid aluminium sun protection system that is mounted outside of glass facades, glass roofs or windows.

Norden Facade puts together all necessary parts to suit the specific property and delivers them ready to mount.

Different lamellae and variations in the spacing between them are used to control the degree of sun protection and transparency. The lamellae can be mounted parallel with or protruding horizontally in front of the vertical glass surfaces or on glass roofs.

Besides the sun protection requirements, particular care is taken to ensure correct connection with the glazing system during the development of Norden Facade SOL. The system fully satisfies the requirements placed in stability, tightness, flexibility and ease of assembly. The loads caused by the sun protection are transferred directly to the supporting structure without exerting any compressive load on the glazing.

The arrangement of the sun protection should be designed to:

- reduce the irradiation energy
- to provide anti-glare
- to ensure the desired transparency
- to allow time-dependent adjustment of the degree of irradiation

Sun position diagrams are available in order to select the suitable lamellae and lamellae spacing.

The sun protection can be mounted on all standard facades and glass roof systems, as well as on solid structures.

Norden Facade SOL sun protection is available in natural aluminium colours or in a powder-coated version. Special colours are possible.

Special separating elements allow zonal opening, raising or folding down of the lamellae for cleaning purposes.

System design

4.1 2

Assembly sequence

1. The sun protection bearings (3) are screwed on to the mullions of the glass facade in predefined intervals. It is necessary to dismantle the cover strips if the system is fitted retroactively.
2. Threaded bars M10 (9), designed to suit the glass thickness, are screwed into the sun protection bearings (3) before the cover strips are fitted.
3. After the cover strips are fitted, a sealing washer and a nut tightened by hand (7) seal off the threaded bar channel and keep the sun protection mounts in a predefined interval from the glazing.
4. The clamping plate (8) is pushed on to the threaded bars and fastened against the sun protection bearing using nuts (3). Different system sizes of the clamping plates allow for variable intervals between the sun protection and the glass.
5. The lamella fork (10) is the connecting piece between the clamping plate and the lamella carrier rail (11). At the same time, the lamella fork is the spacer and pivot bearing for the function 'Cleaning position' of the sun protection lamellae. The lamellae are connected to form one unit and can be folded up and down as required. The size of the zonal units is variable. Gas spring solutions are possible to improve handling.
6. The different lamella types (15) are attached to the lamella carrier rail (11) using lamella holders (13) and mounting brackets (14). Rubber profiles (12) reduce the vibration acting on the supporting structure and hence allow the lamellae to move silently when extending longitudinally. An additional mounting bracket is attached at each point to ensure that longitudinal extension proceeds in one defined direction.

Caption:

1. Timber profile
2. Inner seal GD 62xx / GD 52xx
3. Bearing SZ 0010
4. Screw Z0733
5. Outer seal GD 6024 /GD 5024
6. Cover strip / Upper strip discretionary
7. Washer SZ 0019 / Nut SZ 0109
8. Clamping plate SZ 0037
9. Threaded bar based on glass thickness, e.g. SZ 0151
10. Lamella fork SZ 0041
11. Supporting profile SZ 0003
12. Rubber profile SZ 0009
13. Lamella holder
14. Mounting bracket SZ 0007
15. Sun protection lamella SL 5001

System design

4.1
2

Assembly sequence

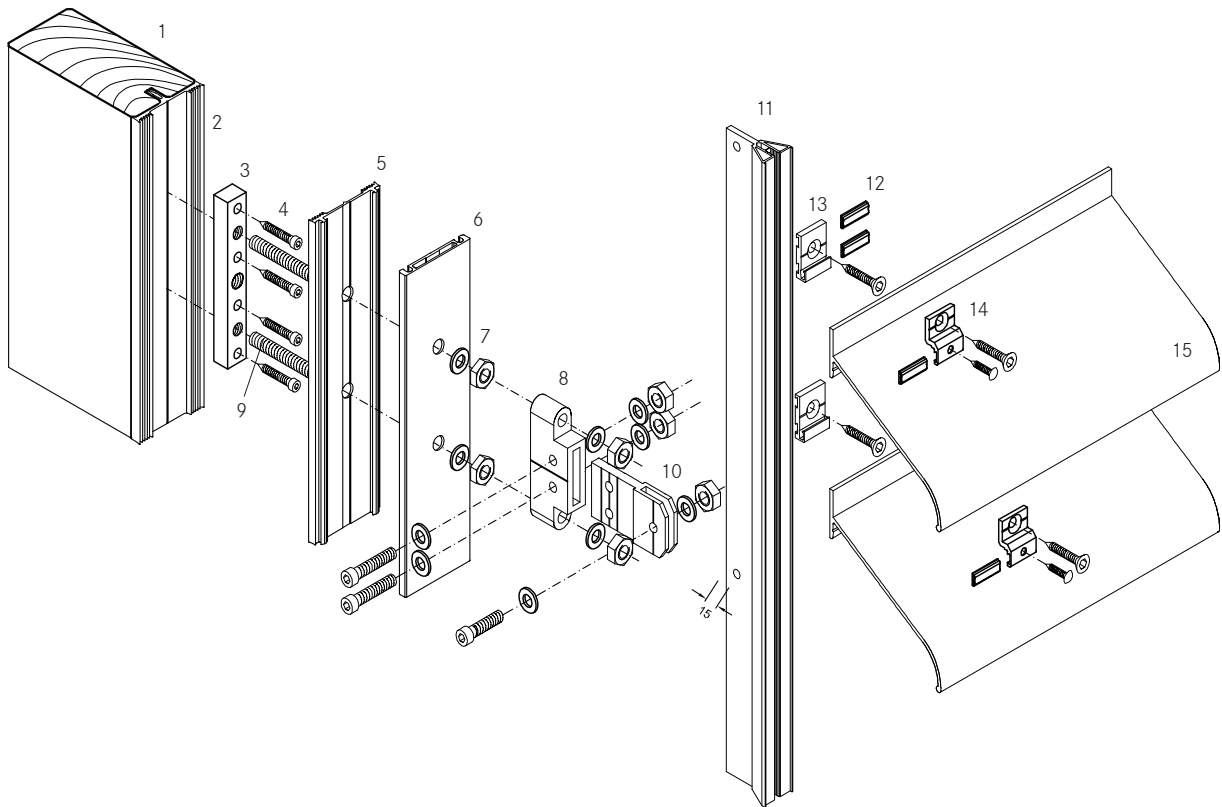

SOL_4.1_002.dwg

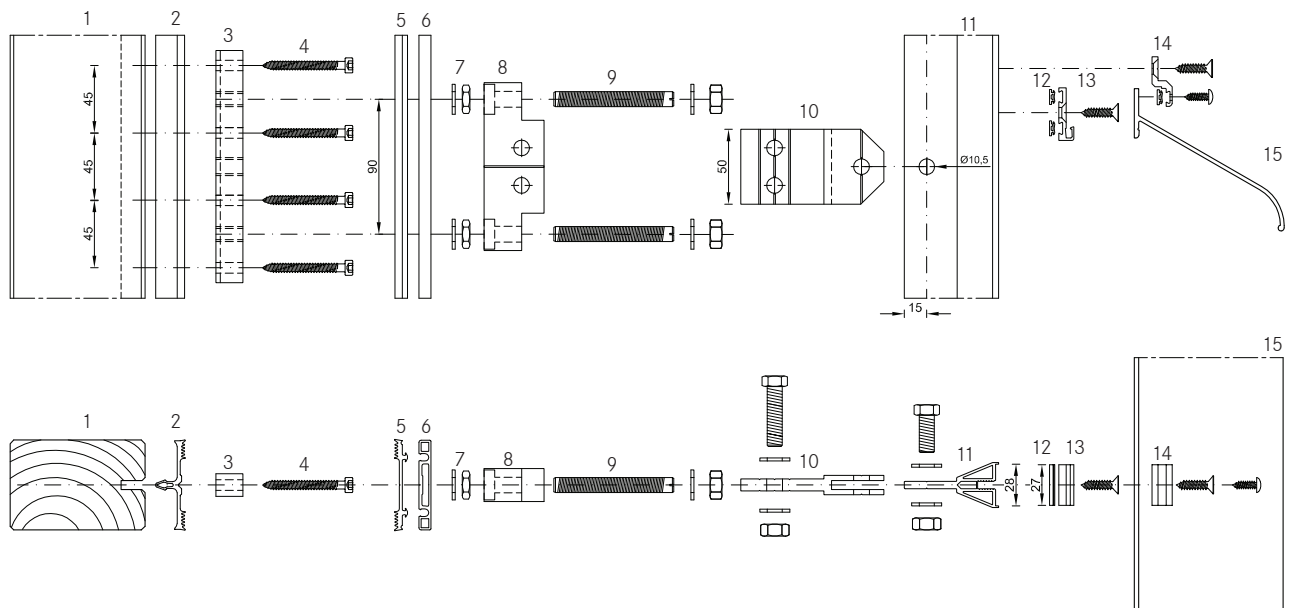

SOL_4.1_009.dwg

Attachment to the building

4.1
3

Stainless steel bearings (refer to the following diagrams) are used to directly connect the Norden Facade SOL sun protection lamellae with the supporting structure vertical to the glass facades or parallel to the glass surface on glass roofs. This requires a free width of at least 15 mm plus a safety clearance to the glass in the glazing groove. Se-cure mounting is necessary, as the entire load of the sun protection system is transferred to the bearings. Static analysis is also necessary. The processor is responsible for attaching the sun protection bearings.

Types of attachment

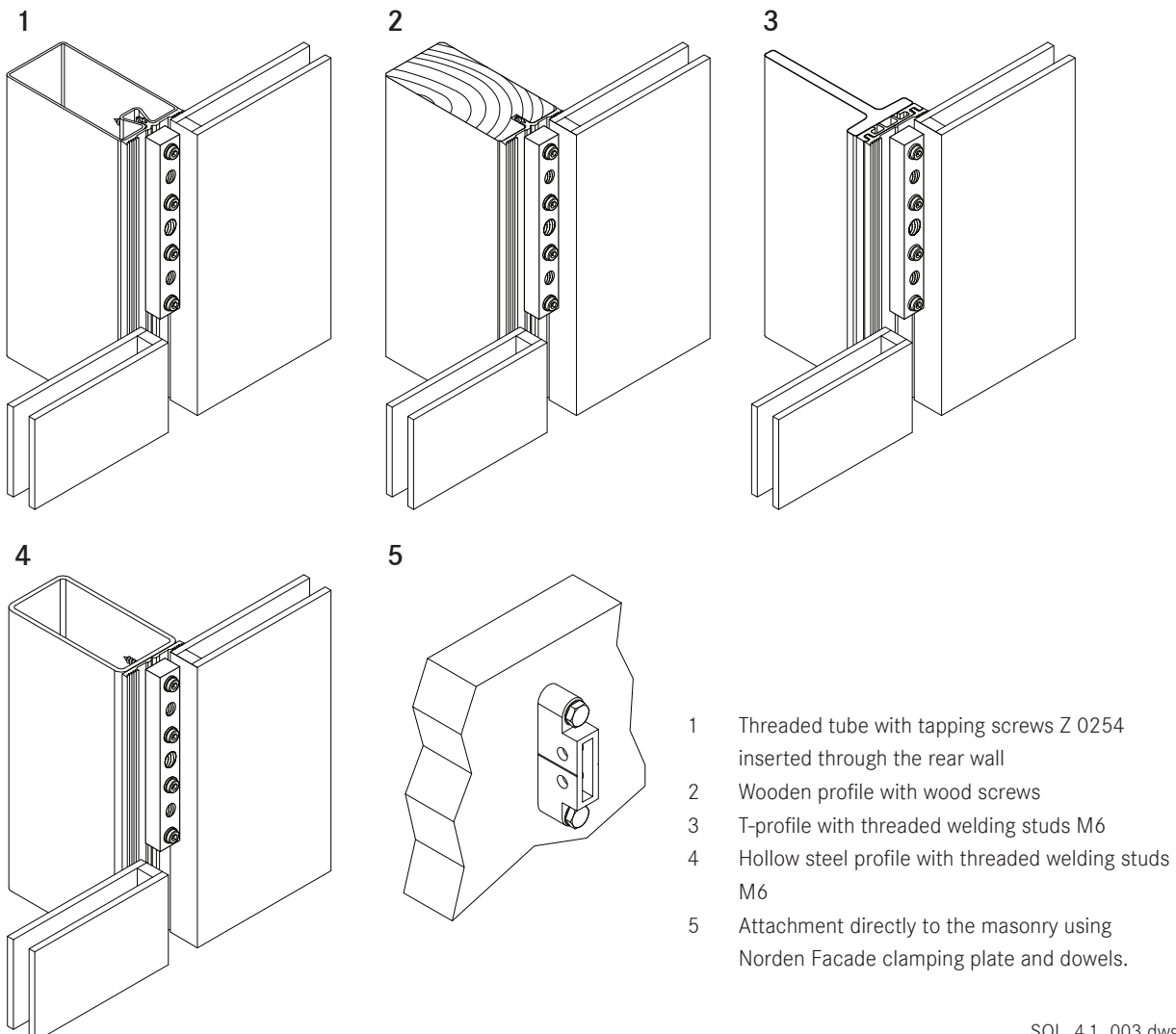

Determining the lamellae spacing

4.1
4

We use IT-assisted sun position calculations to optimise the sun protection systems that we manufacture. The following spacing tables will help you draw up your own plans.

We have considered and weighted two key sun irradiation factors in order to define the lamella spacing. Weak irradiation for a low position of the sun and the corresponding anti-glare effects, as well as the high position of the sun with its more substantial energy irradiation, equivalent to the unwanted thermal load during summer. In our tables, we have compromised between transparency and anti-glare, as additional energy caused by solar irradiation is considered a more positive effect in the cold months of the year. This may lead to glare over the course of the day.

Spacing between the sun protection and the glazing

Various clamping plates can be used to influence the spacing between the sun protection lamellae and the glass. Kindly refer to the table on the following page.

Lamella length

The lamellae can be provided in lengths of up to 6 m. The lamellae are fixed in place with sufficient dilation clearance along their clamped axis. A special double lamella fork and the pairwise arrangement of the lamella carrier rails enable these butt joints. A dual-zone system ensures a favourable lamella sag ratio. Example (SL 5001): Span 2 m → 1.2 mm and 2.8 m → 4.6 mm.

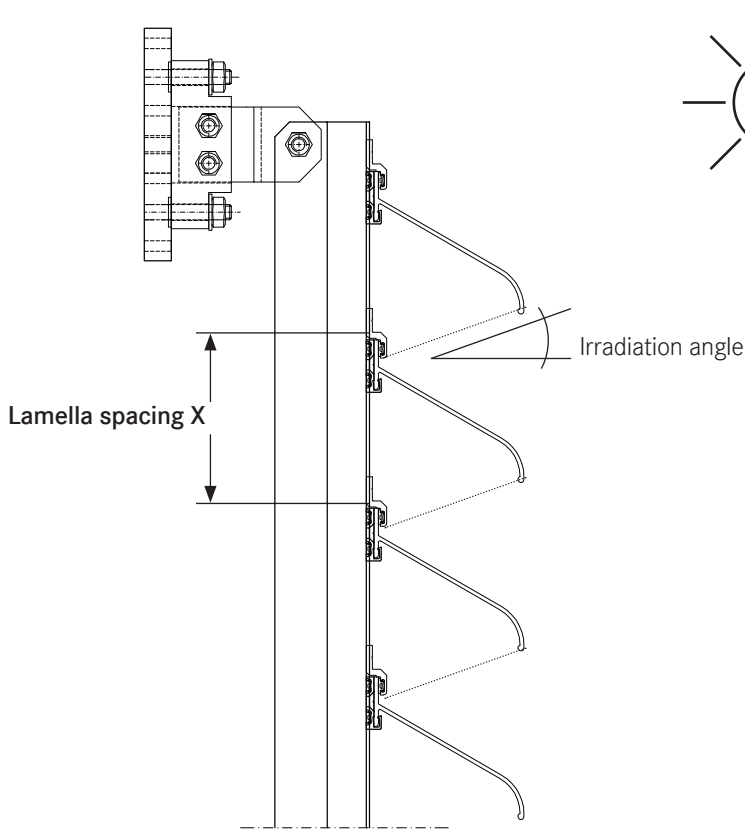

Lamella forms and lamella spacing

4.1
5

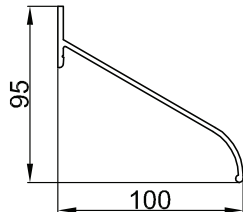

Lamella SL 5001

Lamella form	Span		Proportion of unobstructed view	Depth of the clamping plate	Spacing between cover strip and lamella
	Installation height /m	Free span			
SL 5001	0 - 10	2.8 m	38 - 40%	40 mm	approx. 135 mm
	10 - 100	2.3 m		100 mm	approx. 195 mm
				150 mm	approx. 245 mm

Installation site	Lamella spacing for SL 5001		
	East	South	West
Berlin	160	155	155
Bochum	155	161	164
Bremen	154	161	161
Frankfurt/M.	159	161	161
Hamburg	155	159	159
Hannover	156	160	160
Leipzig	161	156	156
Munich	166	157	157
Stuttgart	161	161	161

Table with values for lamella spacing X in millimetres

Clamping plate spacing

The vertical spacing between the sun protection attachment points on the mullion, i.e. rafters, must not be greater than 2 m.

Cleaning function

4.1
6

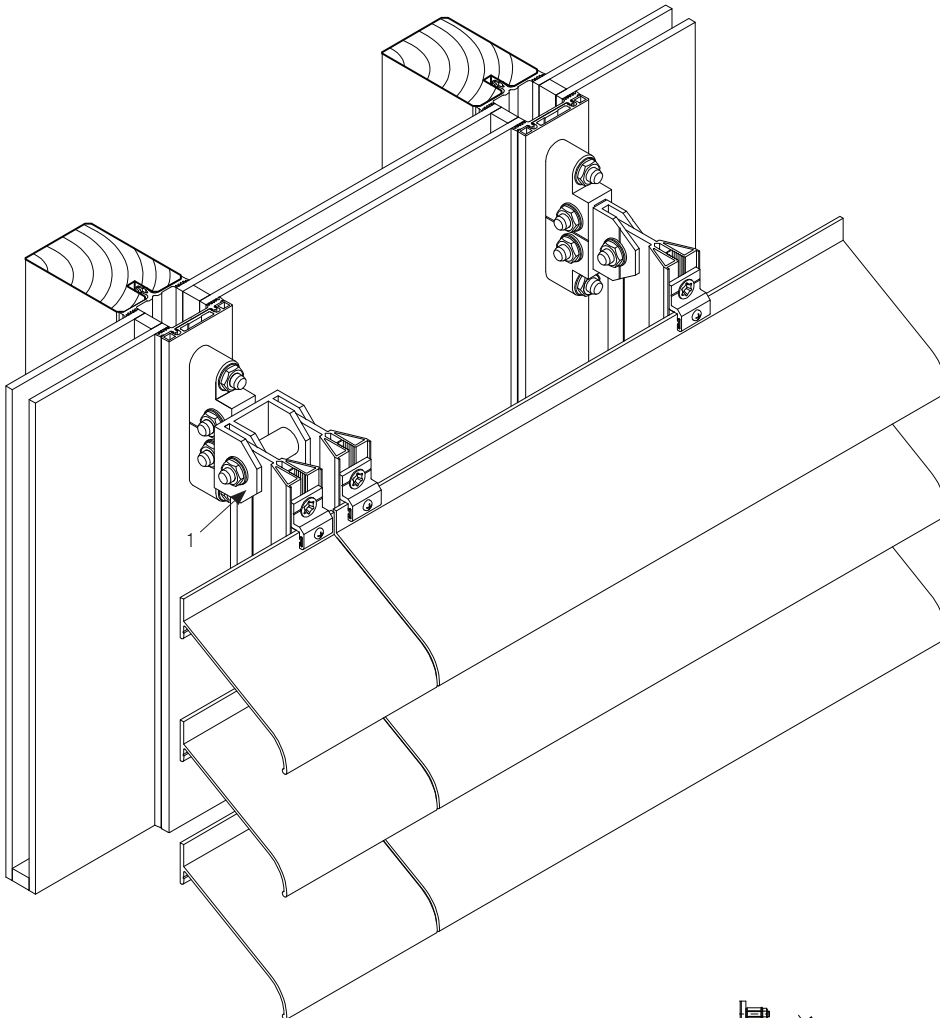

Movable lamella zone

It is advantageous to raise the sun protection in zones in order to clean the glass surface located underneath. The lamella carrier rails must be arranged pairwise for this purpose. Here, a special double lamella fork (1) is used to support the lamella carrier rails. When necessary, the corresponding screw fittings are loosened and the sun protection zone can be raised or folded down by hand. Gas springs increase the ease of use.

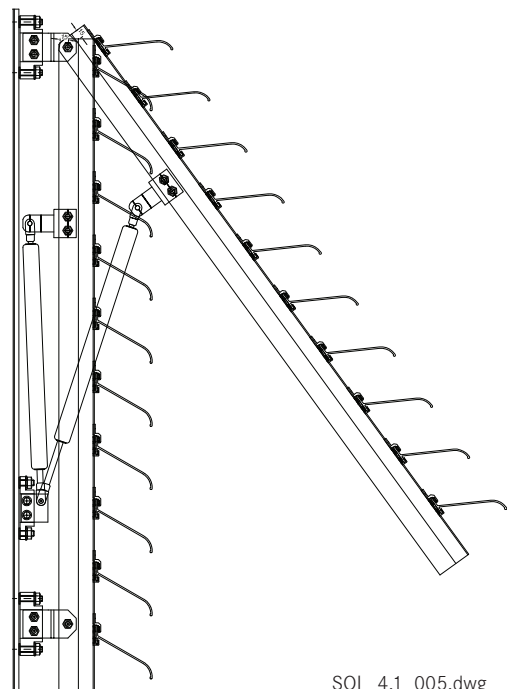

Project planning with Norden Facade SOL

4.2
1

The facade alignment and the passage of the sun at times of the day and the year must be considered when preparing the sun protection project. The first hour after sunrise and the final two hours before sunset can be dis-

regarded in calculating the daily passage of the sun. In our latitudes, the sun is never higher than 15° relative to the horizon during these times. There will be no nuisance caused by energy irradiation in these hours.

Enquiries concerning Norden Facade SOL sun protection

We require the following information from you in order to compile all of the necessary system components correctly: _____

Pos: _____

For BV

1) Lamella type SL 5001 [...]

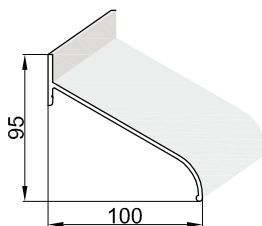

2) Property location

Post code: _____ Town/city: _____ Country: _____

Latitude: _____ ° Longitude: _____ °

3) Installation height of the sun protection

[...] < 5 m [...] > 5 m [...] > 10 m [...] > 20 m [...] > 100 m

4) Alignment of the sun protection (facing the sky)

[...] North [...] East [...] South [...] West
[...] Northeast [...] Southeast [...] Southwest [...] Northwest

5) Inclination of the sun protection surface relative to the perpendicular

_____ °

Project planning with Norden Facade SOL

4.2
1

6) Desired active times for the sun protection system

from _____ until _____ from month _____ to month _____

7) Lamella spacing [in mm]

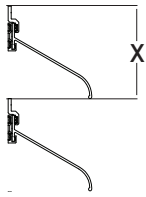



[...] Lamella spacing defined by the customer → Unit "X" = _____ mm

or

[...] Defined by Norden Facade based on a local and in-house calculation of the sun's position

8) Lamella installation alignment

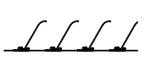
[...] vertical  [...] inclined *Degree of incline* _____  [...] horizontal 

9) Size of the overall sun protection surface (overall)

(Height x width in mm) _____ x _____

Number of sun protection zones _____

10) Mullion/rafter spacing

_____ mm

(Kindly submit any sketches and planning documents).

11) Depth of the clamping plates

Defined by the distance between the cover strip and the lamella

[...] 40 mm [...] 100 mm [...] 150 mm

Project planning with Norden Facade SOL

4.2
1

12) Cleaning function

Easy cleaning of the glass surfaces thanks to zonal folding down of the sun protection system

[...] Yes [...] No

13) Attachment of the sun protection

[...] Norden Facade system

[...] Norden Facade H [...] [...] Norden Facade ZL [...]

Norden Facade SR

Norden Facade AK

[...] alternative facade system

[...] directly on the masonry

Each attachment point will require 2 pcs. M10 threaded bars with at least 35 mm free threaded length to make the attachment. Norden Facade defines the positions of the at-tachment points.

We also supply the sun protection anchors for the Norden Facade glazing systems.

14) Surfaces

The screw fittings are made of rustproof materials. By standard, we deliver aluminium fasteners as 'mill-finished' or 'anodized E6EV1'

[...] all fasteners mill-finished

[...] Lamellae mill-finished

[...] all fasteners in E6EV1

[...] Lamellae in E6EV1

[...] all fasteners in RAL

[...] Lamellae in RAL

15) Sketches/diagrams